

HARVEST DOC™ Cotton



JOHN DEERE

INSTALLATION INSTRUCTIONS Harvest Doc Cotton

PC20423 08APR05 (ENGLISH)

9986 and 9996 Cotton Picker

**John Deere Ag Management Solutions
PC20423 (08APR05)**

COPYRIGHT © 2005
DEERE & COMPANY
Moline, Illinois
All rights reserved
A John Deere ILLUSTRATION® Manual

PC20423-19-08APR05

Introduction

IMPORTANT: Read through instruction thoroughly and familiarize yourself with machine before performing procedure.

Instruction covers the installation of Harvest Doc Cotton components on 9986 and 9996 Cotton Picker.

OUO6050,00009BA -19-08MAR05-1/1

Parts Listing

NOTE: GreenStar components are required but sold separate from sensor bundle.

GreenStar Components

- Display
- Mobile Processor
- KeyCard, Harvest Doc Cotton
- Data Storage Card
- JD Office 1.4
- StarFire or StarFire iTC Receiver

BN272475 6-row Bundle

- AH211594 StarFire Receiver Bracket
- PF10607 Display Bracket
- AN277750 Sensor Harness
- AN278523 Outer Sensor Bracket
- N375056 Outer Sensor Support
- N375057 Inner Sensor Bracket
- N375058 LH Inner Sensor Support
- N375717 RH Inner Sensor Support
- AN278822 Hardware Kit
- AN278232 Y-Harness
- PF80799 Cotton Mass Flow Sensor (CMFS)
- PF80607 Sensor Combiner Module (SCM)
- Operator's Manual
 - PC20427 (or higher) English
 - PC204278 (or higher) Portuguese
 - PC20429 (or higher) Spanish
- PF11740 Quick Reference Guide

BN272476 4-row Bundle

- AH211594 StarFire Receiver Bracket
- PF10607 Display Bracket
- AN278784 Sensor Harness
- AN278523 Outer Sensor Bracket
- N375056 Outer Sensor Support
- N375057 Inner Sensor Bracket
- N375058 LH Inner Sensor Support
- N375717 RH Inner Sensor Support
- AN278822 Hardware Kit
- AN278232 Y-Harness
- PF80799 Cotton Mass Flow Sensor (CMFS)
- PF80607 Sensor Combiner Module (SCM)
- Operator's Manual
 - PC20427 (or higher) English
 - PC204278 (or higher) Portuguese
 - PC20429 (or higher) Spanish
- PF11740 Quick Reference Guide

AN27822 Hardware Kit

- E63525 Lock Nut, Flange, 8 X 1.25 mm (36 Used)
- E63526 Nut, 10 X 1.5 mm (10 Used)
- H77698 Strap, Self-locking (30 Used)
- N275620 Cap Screw, Flange, 10 X 1.5 X 2 mm (10 Used)
- N275830 Cap Screw, Flange, 8 X 25 mm (36 Used)
- T27550 Clamp, Pressure Line (6 Used)

OUO6050,0000504 -19-24AUG04-1/1

StarFire Receiver Bracket

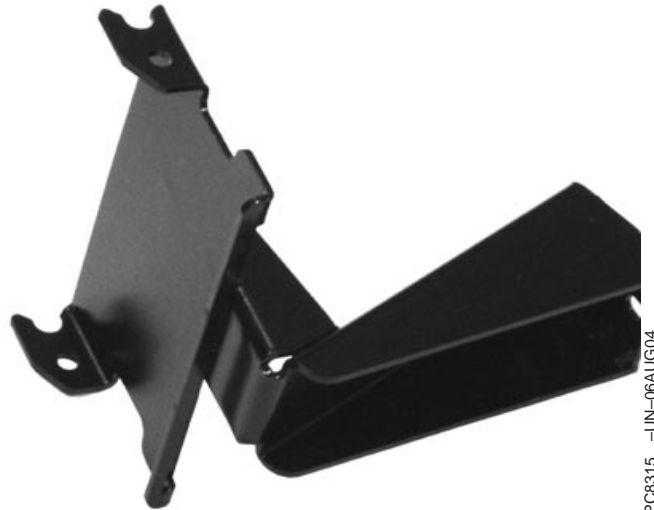

PC8315 -UN-06AUG04

StarFire Receiver Bracket

OUO6050,0000C8C -19-01FEB05-1/1

Display Bracket



PC8308 -UN-24AUG04

Display Bracket

OUO6050,0000C8D -19-01FEB05-1/1

Sensor Harness



Sensor Harness

PC8306 -UN-06AUG04



CMFS Connector and Ground

PC8307 -UN-06AUG04



Terminator Replacement Connector

PC8318 -UN-06AUG04

OJ06050,0000C8E -19-01FEB05-1/1

Outer Sensor Bracket and Support



Sensor Bracket

PC8311 -UN-24AUG04



Sensor Support

PC8305 -UN-24AUG04

NOTE: This bracket configuration will be used to mount the CMFS on outer ducts located on both sides of cab. This configuration will not be used for ducts directly behind the cab.



Sensor Bracket, Support, and CMFS

PC8321B -UN-17MAR05

OUO6050,0000C8F -19-07MAR05-1/1

Inner Sensor Bracket and Supports



LH and RH Inner Sensor Support

PC8310 -UN-24AUG04



Inner Sensor Bracket

PC8309 -UN-10JAN05

NOTE: This bracket configuration will be used to attach the CMFS on the inner ducts which are located directly behind the cab. Machines set to narrow row spacings require the use of two inner bracket assemblies. Machines set to wide row spacings only require one inner bracket assembly.



Inner Sensor Bracket and Supports

PC8488B -UN-21MAR05

OOU6050,0000C90 -19-07MAR05-1/1

Y-harness

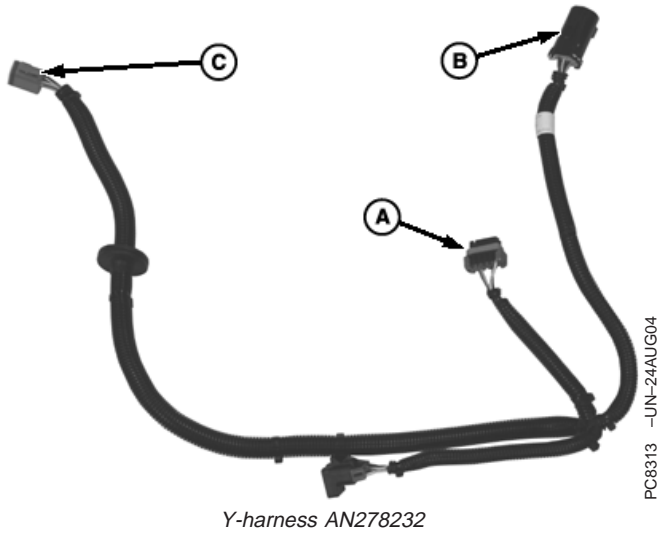

Y-harness AN278232

- A—SCM Connector
- B—Terminator Replacement Connector
- C—StarFire or StarFire iTC Receiver Connector



(A) SCM Connector

PC8312 -UN-06AUG04



(B) Terminator Replacement Connector

PC8318 -UN-06AUG04



(C) StarFire or StarFire iTC Receiver Connector

PC8319 -UN-06AUG04

OJ06050,00009BC -19-08MAR05-1/1

Cotton Mass Flow Sensor (CMFS)



Cotton Mass Flow Sensor (CMFS) PF80799

PC8231B -UN-17MAR05

OOU6050,00009BE -19-17MAR05-1/1

Sensor Combiner Module (SCM)



Front

PC8314 -UN-06AUG04

PC8320 -UN-06AUG04



Back

OOU6050,0000C91 -19-01FEB05-1/1

Setup Time

Average installation time for bundle is:

- 3 hours for SN16,001 and above
- 5 hours for SN16,00 and below

OOU6050,00009BB -19-24AUG04-1/1

Prepare Machine

Remove ignition key.

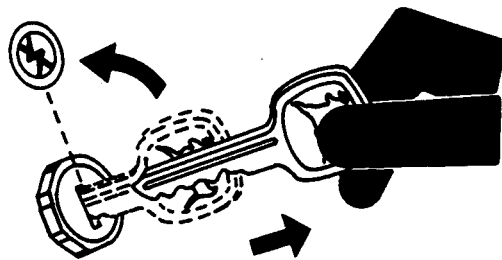

TS230 -JUN-24MAY89

OUC6050,00009BC -19-03JUN04-1/1

Initial Machine Configuration

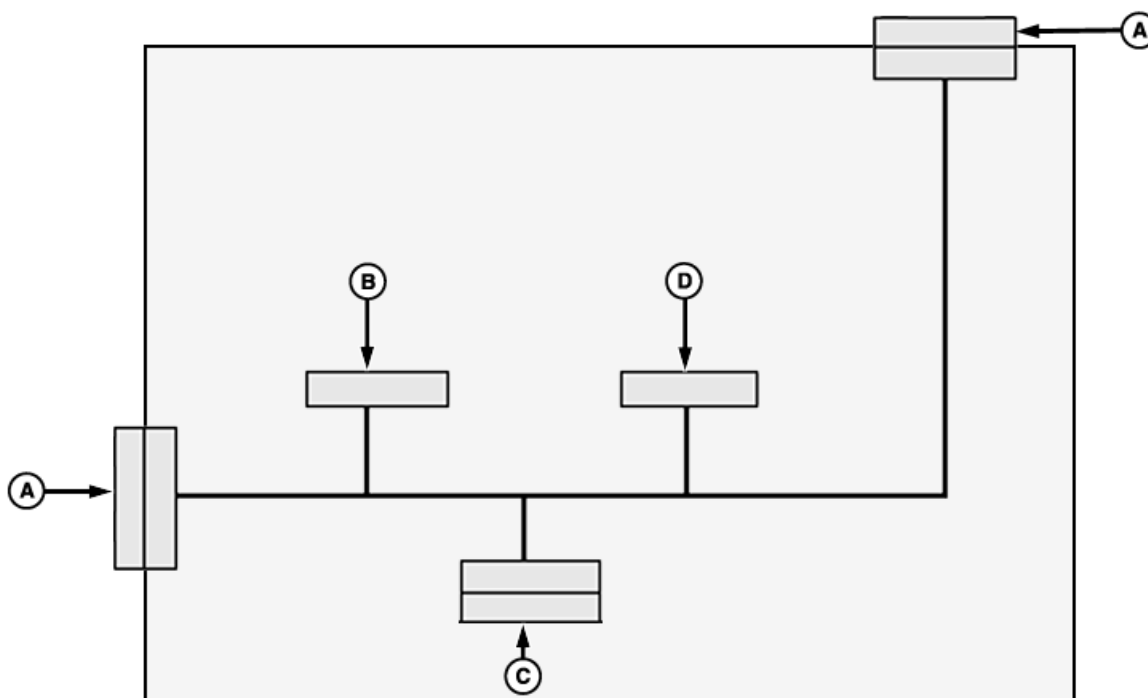

A—Terminator

B—Display Connector

C—Cotton Picker Devices and Controllers

D—Mobile Processor Connector

Diagram shows cab harness with no Harvest Doc Cotton components installed. The cab harness is standard equipment and installed at the factory. Harness includes connectors for display and mobile

processor. When display and processor are not present, connectors are hidden up under right front corner of cab headliner.

PC8081 -JUN-19FEB04

OUC6050,00005BE -19-23JUN04-1/1

Harvest Doc Configuration

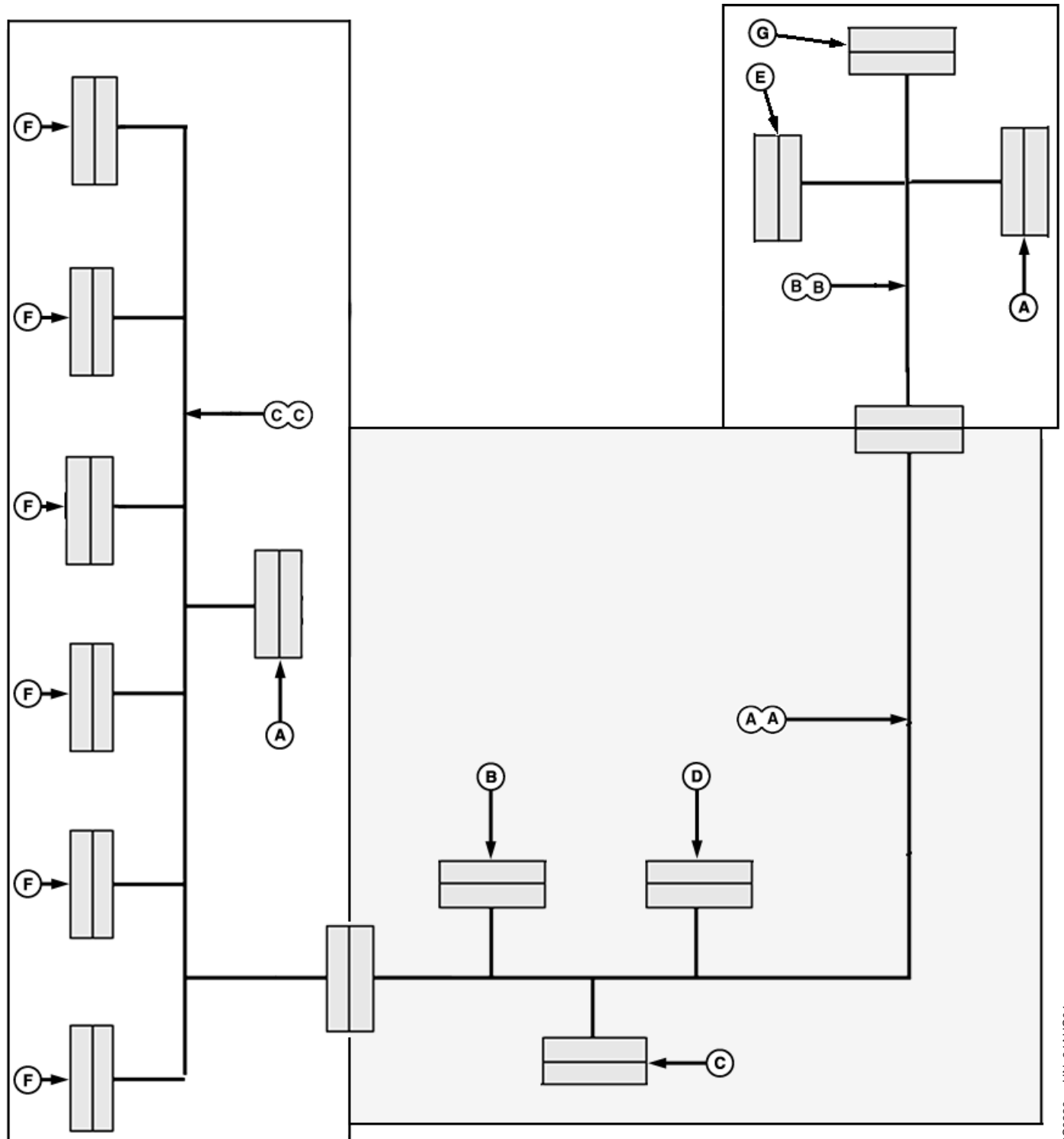

AA—Cab Harness
 BB—Y-harness (AN278232)
 CC—Sensor Harness

A—Terminator
 B—Display
 C—Cotton Picker Devices and
 Controllers

D—Mobile Processor
 E—SCM (PF80607)
 F—Sensor (PF80799)

G—StarFire or StarFire iTC
 Receiver

Continued on next page

OOU6050,00005BF -19-24AUG04-1/2

Diagram shows Cab harness (AA) (in shaded box), Y-harness (BB), and Sensor harness (CC). New harnesses (BB) and (CC) are installed by removing terminators from Cab harness and plugging new

harnesses into connection point. Y-harness and Sensor harness have built-in terminators so removed terminator can be discarded.

OOU6050,00005BF -19-24AUG04-2/2

Y-harness

1. Remove front of cab headliner, exposing front terminator of cab harness and a short length of harness with plugs for display and mobile processor.
2. Unplug terminator from cab harness located above right-hand side front corner post.



Terminator

PC8089 -UN-19FEB04

OOU6050,0000CDB -19-08MAR05-1/3



Y-harness

PC8085 -UN-24AUG04



SCM PF80607

PC8083 -UN-18FEB04

NOTE: 8-pin connector on SCM is NOT used.

3. Attach SCM to Y-harness using 10-pin connection.

4. Attach Y-harness to connector on cab harness where terminator was removed. Discard terminator.

Continued on next page

OOU6050,0000CDB -19-08MAR05-2/3

5. Insert SCM and Y-harness above headliner and right front corner post of cab.



PC8090 -UN-19FEB04

OOU6050,0000CDB -19-08MAR05-3/3

Display and Mobile Processor

1. Install washer (A) and cap screw (B) on top display mounting hole.

- A—Flat Washer
- B—Phillips Head Cap Screw

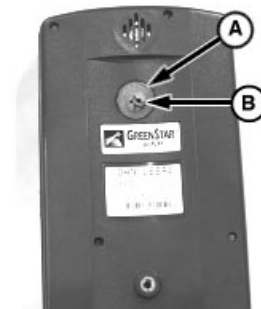

H62529 -UN-03FEB00

OOU6050,0000C81 -19-10JAN05-1/6

2. Raise cover (A), and align points (B and C).

- A—Cover
- B—Point
- C—Point



H62540 -UN-03FEB00

Continued on next page

OOU6050,0000C81 -19-10JAN05-2/6



A—Cover

H62541 -UN-03FEB00

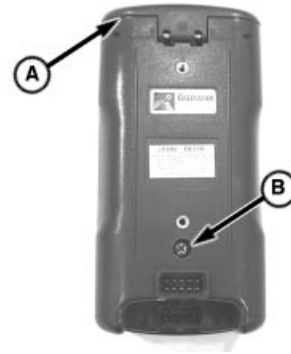

B—Phillips Head Cap Screw

H62542 -UN-03FEB00

3. Put two halves together and close top cover (A).

4. Install cap screw (B).

OOU6050,0000C81 -19-10JAN05-3/6

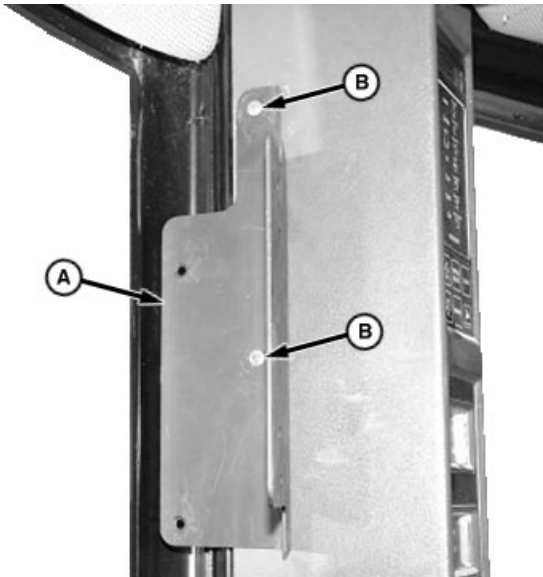

A—Display Bracket PF10607

H64439B -UN-21MAR05

B—Screw (2 Used)



PC8489 -UN-10JAN05

5. Install display (A) as shown, retain with existing hardware (B).

Continued on next page

OOU6050,0000C81 -19-10JAN05-4/6

6. Retain display/processor to bracket with cap screws (A).

IMPORTANT: Grey connector (B) plugs into mobile processor. Black connector (C) plugs into display.

7. Plug wiring harness connectors (B) into back of display/processor.
8. Install front headliner and overhead control panel.

A—Cap Screw (2 used)
B—Grey Mobile Processor Connector
C—Black Display Connector

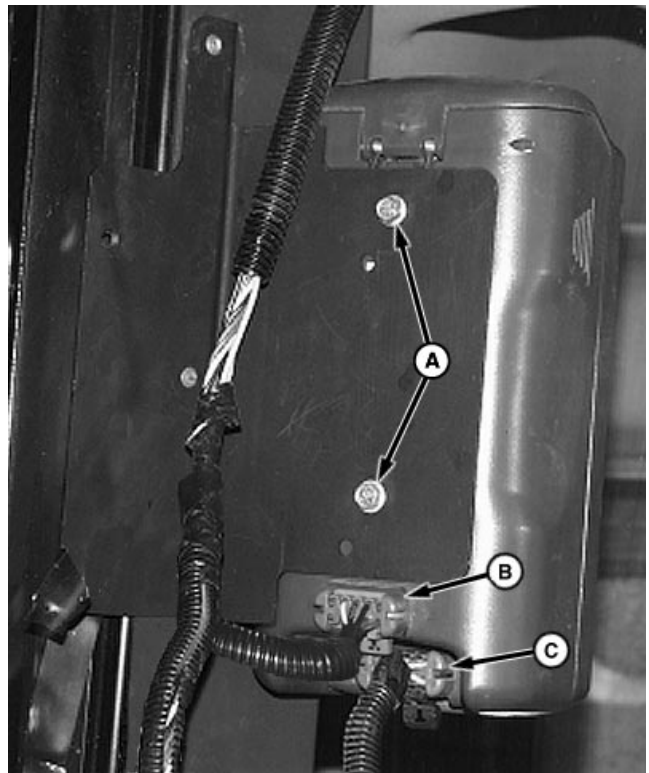

OUC6050,0000C81 -19-10JAN05-5/6

9. Insert KeyCard and PC Data Storage Card into mobile processor. Cards may be inserted with either one in the front.

A—KeyCard
B—PC Data Storage Card

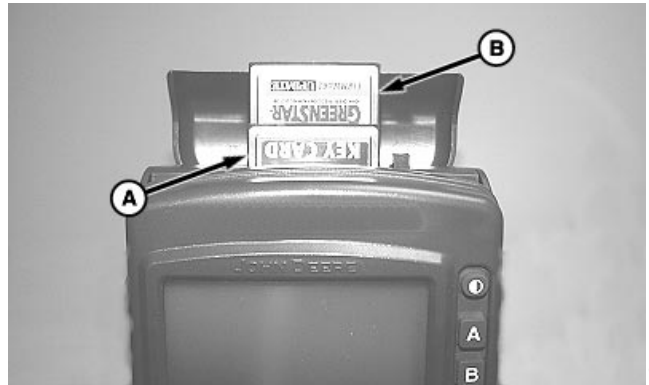

OUC6050,0000C81 -19-10JAN05-6/6

StarFire or StarFire iTC Receiver

2001, 2002, and 2003 Machines (SN16,000 and below)

1. Place a piece of tape along windshield wiper blade on window to aid in reassembly of wiper arm. Remove wiper arm (A).
2. Remove rubber boot, nut (B), cap screws (C), handle and bracket.

⚠ CAUTION: Avoid serious injury or death from electric shock or lamp explosion if equipped with HID-Xenon lights. This lamp is powered by 25,000 volts. Be sure lights are turned off, engine is turned off, key is removed and appropriate eye protection is worn before working around or with HID-Xenon lights.

3. Remove cap screws (D) and lower fascia to disconnect light connectors and windshield washer hose connections. Remove fascia.

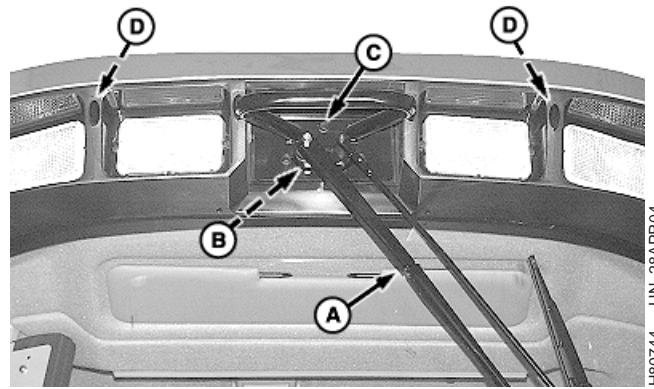

A—Wiper Arm
B—Nut
C—Cap Screw (3 used)
D—Screw (8 used)

H80744 -UN-28APR04

OOU06050,00009B9 -19-24AUG04-1/13

4. Drill a 8 mm hole into handle brace, centered vertically with existing hole, using dimension (A).

A—Dimension—11 mm (0.43 in.)

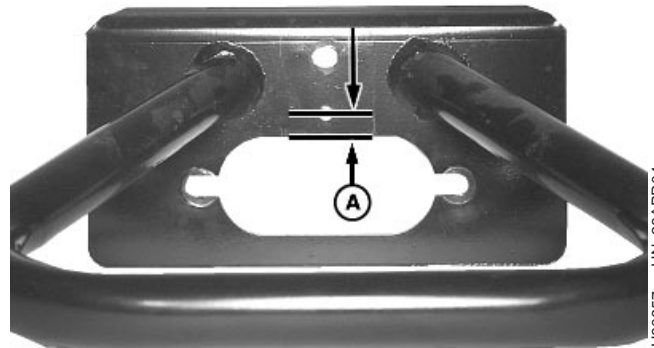

Continued on next page

OOU06050,00009B9 -19-24AUG04-2/13

H80657 -UN-28APR04

5. Drill a 68 mm hole (A) using dimensions (B and C) in cab roof.

A—Hole
B—Dimension—89 mm (3.5 in.)
C—Dimension—76 mm (3 in.)

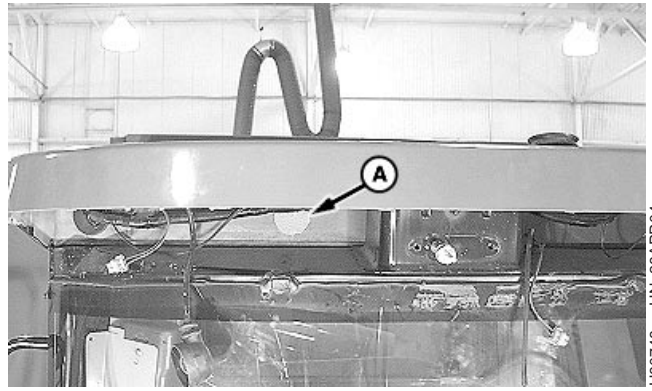

H80748 -UN-28APR04

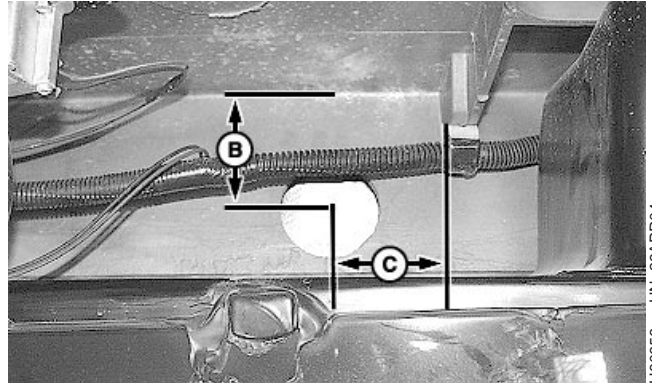

H80656 -UN-29APR04

OOU6050,00009B9 -19-24AUG04-3/13

6. Drill a 42 mm hole in upper right-hand corner of pocket by wiper arm assembly hole using dimensions (A and B) in fascia.
7. Route Y-harness (A) over rib through hole drilled in cab roof.

A—Dimension—35 mm (1.38 in.)
B—Dimension—35 mm (1.38 in.)

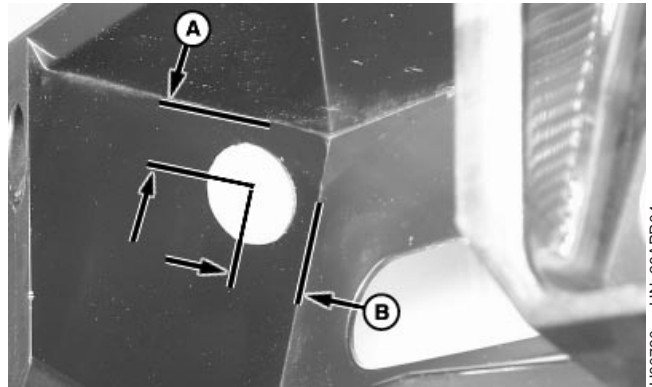

H80730 -UN-28APR04

Continued on next page

OOU6050,00009B9 -19-24AUG04-4/13

8. Install rubber boot (A).
9. Connect cab lights and windshield washer hoses to cab fascia.
10. Route StarFire or StarFire iTC Receiver connector (B) through hole in cab fascia and install rubber grommet.
11. Install fascia, handle, and wiper assembly. Use piece of tape as reference point when reinstalling wiper arm. Adjust as required. Tighten main arm lock nut to specification.

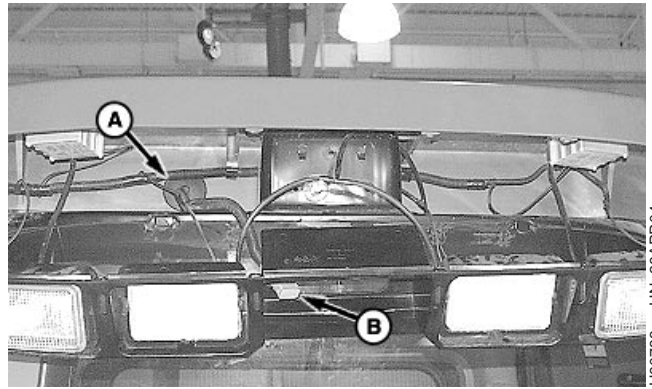

H80733 -UN-28APR04

A—Rubber Boot
B—Connector

Specification

Windshield Wiper Main Arm Lock
Nut—Torque 18 N•m
(159 lb-in.)

OUO6050,00009B9 -19-24AUG04-5/13

12. Attach receiver bracket with previously removed hardware and self-tapping screw.

A—Existing Hardware
B—Screw, Self-tapping

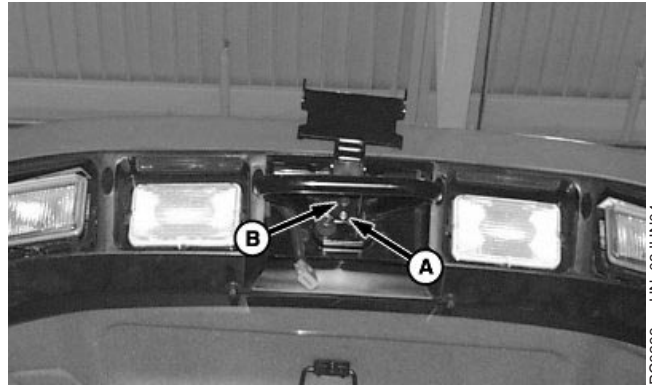

PC8233 -UN-03JUN04

OUO6050,00009B9 -19-24AUG04-6/13

13. Install StarFire or StarFire iTC Receiver (A) on front of cab by aligning pin (B) (both sides) on quick coupler with slots in receiver bracket.
14. Push down on StarFire or StarFire iTC Receiver to engage latch (C).

A—StarFire or StarFire iTC Receiver
B—Pin
C—Latch

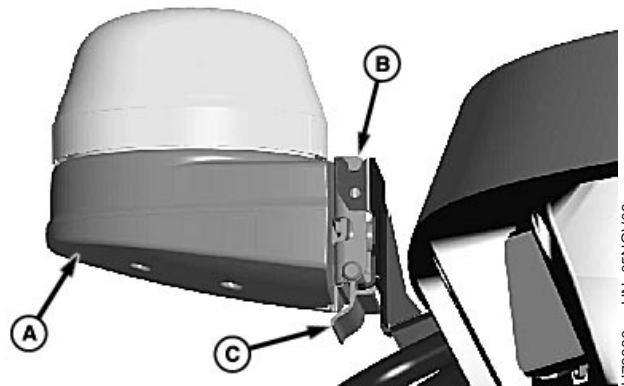

H78886 -UN-05NOV03

Continued on next page

OUO6050,00009B9 -19-24AUG04-7/13

15. Plug Y-harness (A) into StarFire or StarFire iTC Receiver harness (B).
16. Install front headliner and overhead control panel.

A—Y-harness
B—StarFire or StarFire iTC Receiver Harness

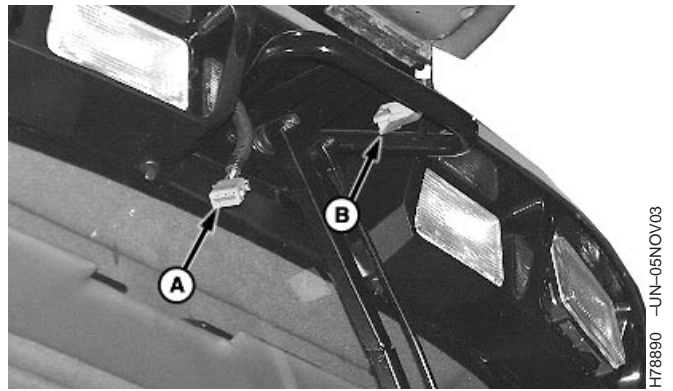

H78890 -UN-05NOV03

OOU06050,00009B9 -19-24AUG04-8/13

2004 and Newer Machines (SN 16,001 and above)

1. Place a piece of tape along windshield wiper blade on window to aid in reassembly of wiper arm. Remove wiper arm (A).
2. Remove rubber boot, nut (B), cap screws (C), handle and bracket.

CAUTION: Avoid serious injury or death from electric shock or lamp explosion if equipped with HID-Xenon lights. This lamp is powered by 25,000 volts. Be sure lights are turned off, engine is turned off, key is removed and appropriate eye protection is worn before working around or with HID-Xenon lights.

3. Remove cap screws (D) and lower fascia to disconnect light connectors and windshield washer hose connections. Remove fascia.
4. Route Y-harness over rib through hole in cab roof.

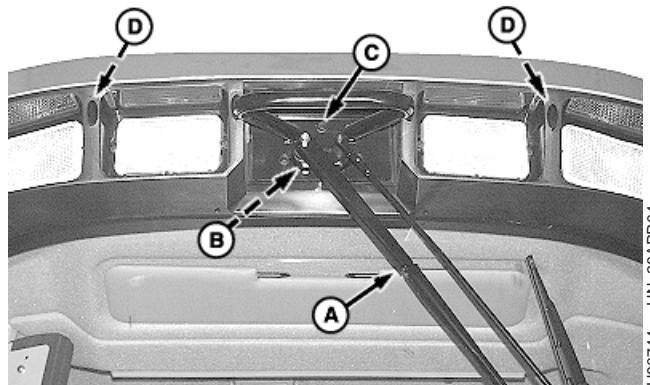

H80744 -UN-28APR04

A—Wiper Arm
B—Nut
C—Cap Screw (3 used)
D—Screw (8 used)

Continued on next page

OOU06050,00009B9 -19-24AUG04-9/13

5. Install rubber boot (A).
6. Connect cab lights and windshield washer hoses to cab fascia.
7. Route Y-harness connector (B) through hole in cab fascia and install rubber grommet.
8. Install fascia, handle, and wiper assembly. Use piece of tape as reference point when reinstalling wiper arm. Adjust as required. Tighten main arm lock nut to specification.

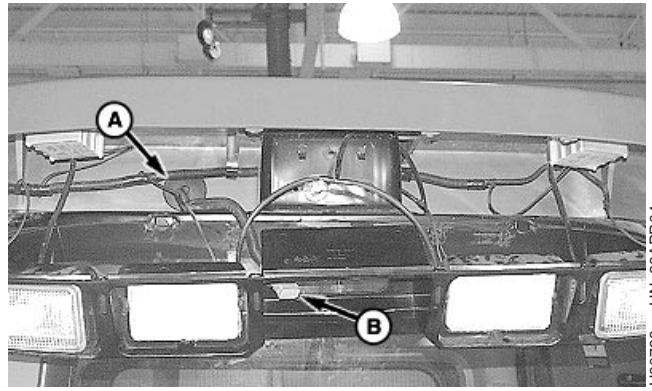

H80733 -UN-28APR04

A—Rubber Boot
B—Connector

Specification

Windshield Wiper Main Arm Lock
Nut—Torque 18 N•m
(159 lb-in.)

OOU6050,00009B9 -19-24AUG04-10/13

9. Attach StarFire Receiver bracket with previously removed hardware and self-tapping screw.

A—Existing Hardware
B—Screw, Self-tapping

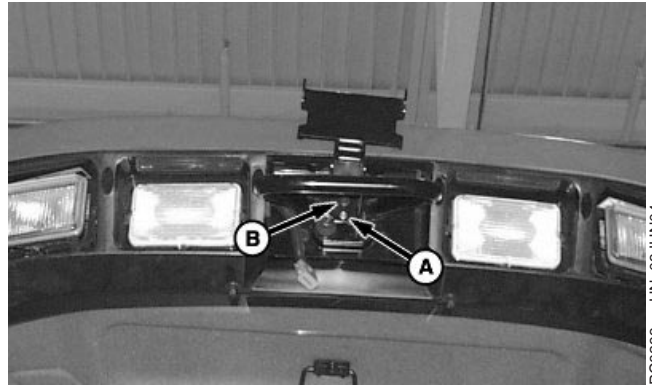

PC8233 -UN-03JUN04

OOU6050,00009B9 -19-24AUG04-11/13

10. Install StarFire or StarFire iTC Receiver (A) on front of cab by aligning pin (B) (both sides) on quick coupler with slots in StarFire Receiver bracket.
11. Push down on position StarFire or StarFire iTC Receiver to engage latch (C).

A—StarFire or StarFire iTC Receiver
B—Pin
C—Latch

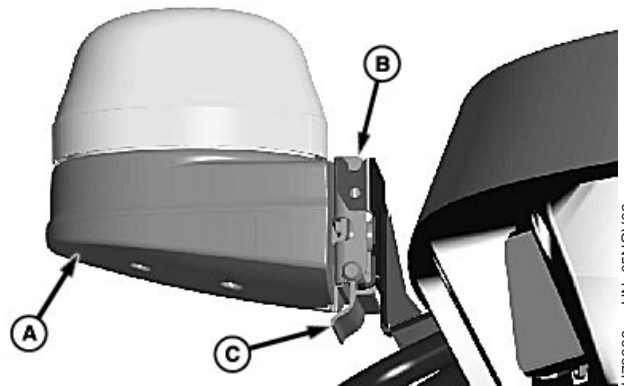

H78886 -UN-05NOV03

Continued on next page

OOU6050,00009B9 -19-24AUG04-12/13

12. Plug Y-harness (A) into StarFire receiver harness (B).

- A—Y-harness
- B—StarFire Receiver Harness

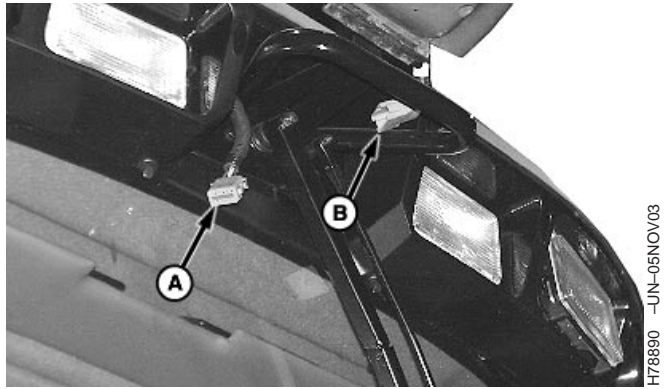

H78890 -UN-05NOV03

OOU6050,00009B9 -19-24AUG04-13/13

Sensors

1. Locate controller pan under the cab.
2. Remove screws attaching pan.
3. Route terminator and stub harness out of pan.
4. Reinstall pan with terminator exposed.

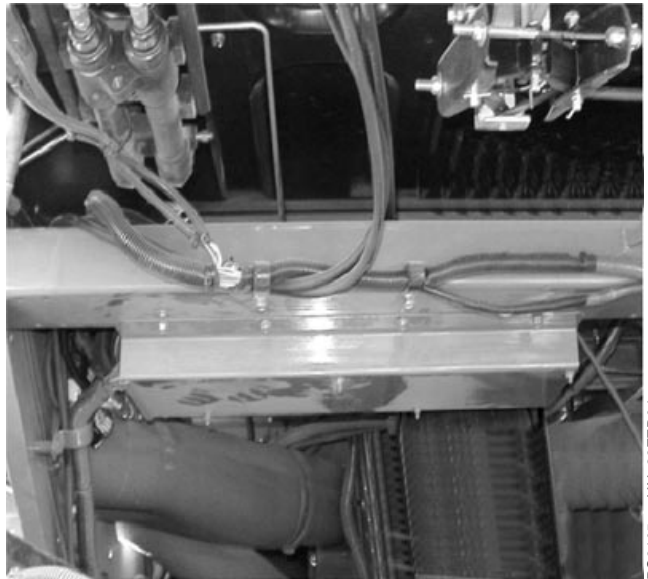

PC8105 -UN-23FEB04

OOU6050,00005C1 -19-27AUG04-1/9

5. Remove terminator from cab harness and discard. The sensor harness has a built in terminator.



PC8093 -UN-23FEB04

Continued on next page

OOU6050,00005C1 -19-27AUG04-2/9

- Sensor harness must have a solid chassis ground connection (A). Ground connection is provided by a separate wire from harness. Separate wire is connected directly to each sensor to control electrostatic discharge.

A—Ground Connection

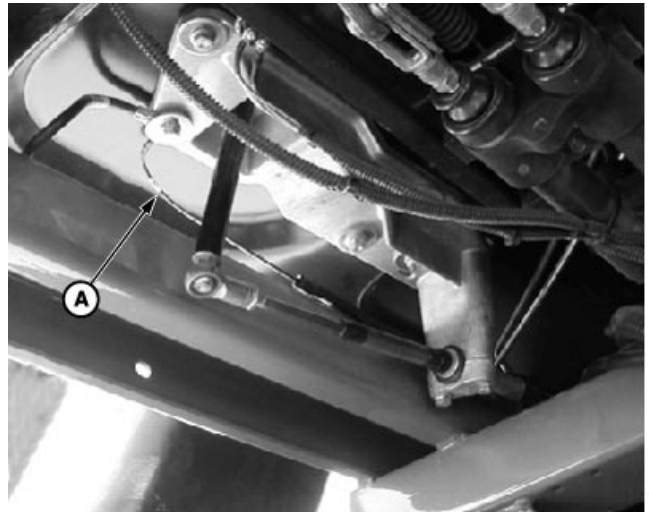

PC8094 -UN-02JUN04

OOU6050,00005C1 -19-27AUG04-3/9

- Sensor harness is routed up to sensors using U-channel on right rear of cab.



PC8095 -UN-23FEB04

Continued on next page

OOU6050,00005C1 -19-27AUG04-4/9

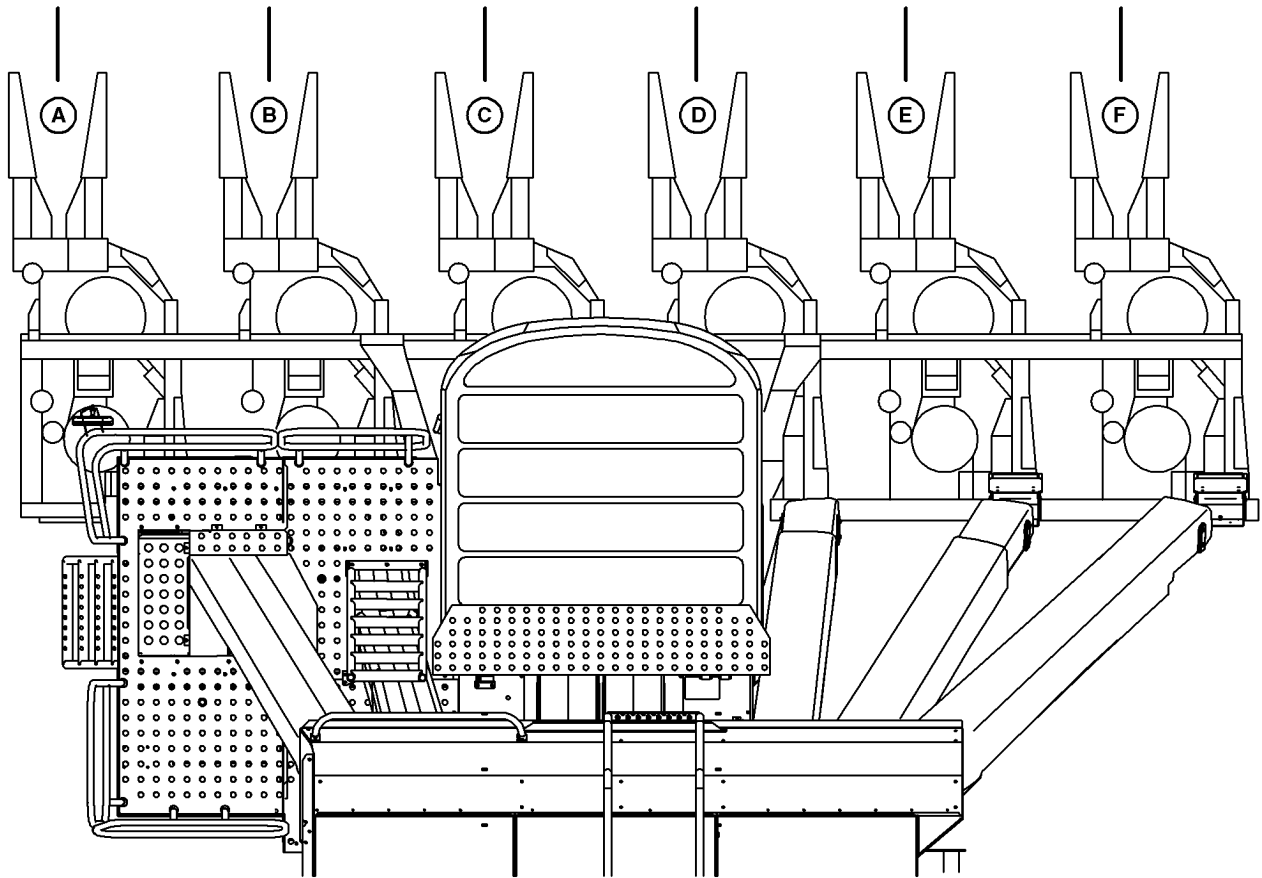

NOTE: Four-Row Machines—sensor harness will be connected in the same way with left unit being #1.

8. Sensor harness is channeled to each sensor by routing along basket lift bar. There is a breakout stub harness for each sensor. Connectors will be labeled 1-6 corresponding to the row sensor they should be attached to.

9. Sensors are mounted to each cotton picker row using two styles of metal mounting brackets:

- **Outer Sensor Bracket (AN278523) and Support (N375056)** Used to attach sensors to out ducts on each side of cab. Bracket is bolted to plate that secures duct to lift bar. Support is attached from bracket to plate to provide rigidity.

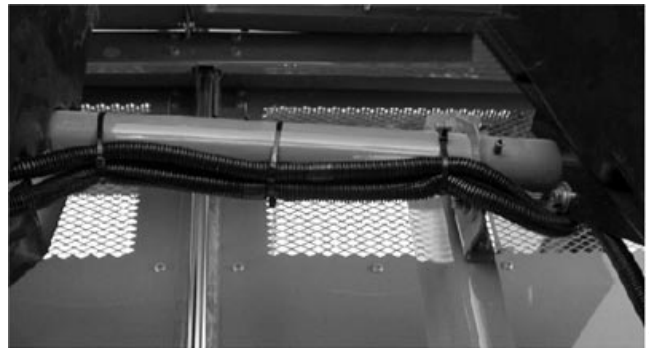

Basket Lift Bar

- **Inner Sensor Bracket (N375057) and Supports (N375058)(N375717)** A three piece bracket consisting of inner sensor bracket connected to right and left supports. Supports are secured to basket lift bar. Bracket is attached to supports..

OOU6050,00005C1 -19-27AUG04-6/9

10. **Outer Sensor Bracket (AN278523) and Support (N375056):** Attach sensor bracket (A) and sensor support (B) to plate that secures duct to raise bar using existing hardware.
11. Attach bracket and support together with 10 x 1.5 mm cap screws (C) and nuts.

- A—Sensor Bracket
- B—Sensor Support
- C—Cap Screw, 10 x 1.5 mm (2 Used Per Unit)

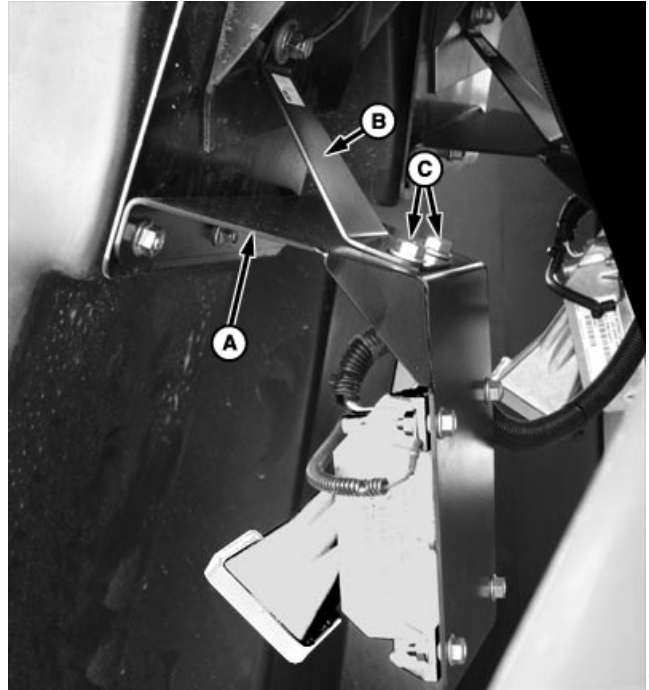

PC8326B -UN-21MAR05

Continued on next page

OOU6050,00005C1 -19-27AUG04-7/9

12. **Inner Sensor Bracket (N375057) and Supports (N375058)(N375717):**

- **Narrow Row Machine Spacing:** Require two inner sensor bracket assemblies.
- **Wide Row Machine Spacing:** Require only one inner sensor bracket assembly. Spare set of inner sensor brackets is not used.

The inner sensor bracket is used to attach sensors to inner ducts directly behind cab. It is a three piece bracket that includes inner sensor bracket and two sensor supports.

Attach inner sensor bracket (A) to the inner sensor supports (B) with four 8 x 25 mm cap screws and flange nuts.

Attach inner sensor support to basket lift bar (C).

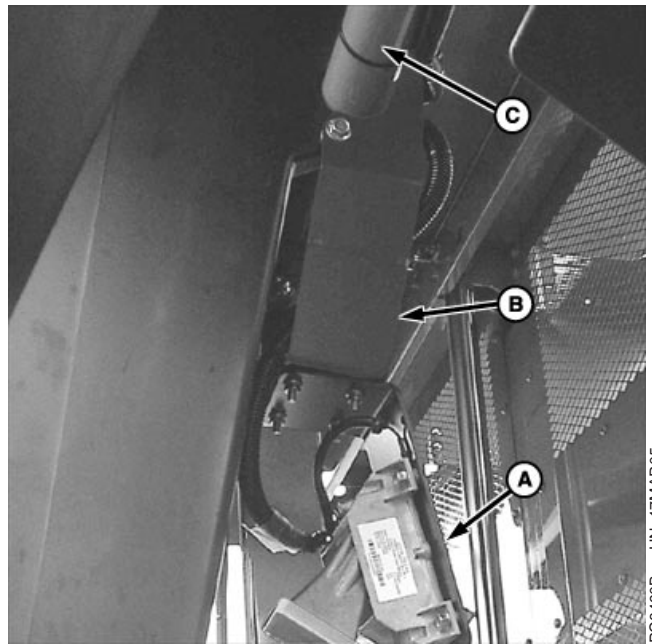

A—Inner Sensor Bracket
B—Inner Sensor Supports
C—Basket Lift Bar

Continued on next page

OOU6050,00005C1 -19-27AUG04-8/9

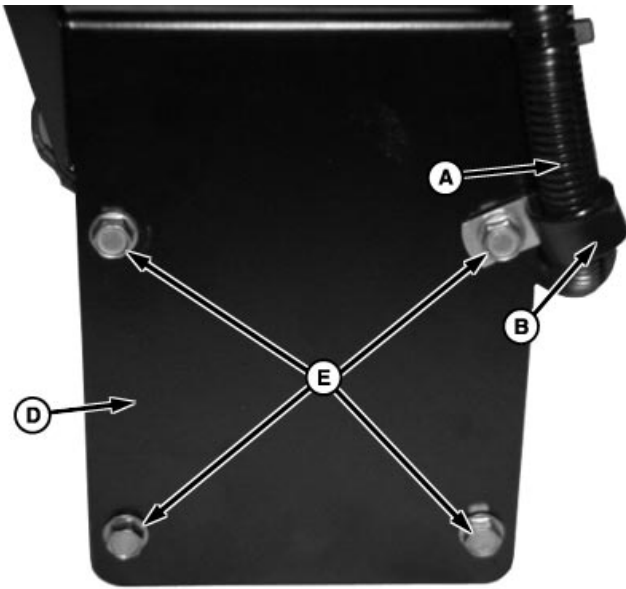

PC8304 -JUN-06AUG04

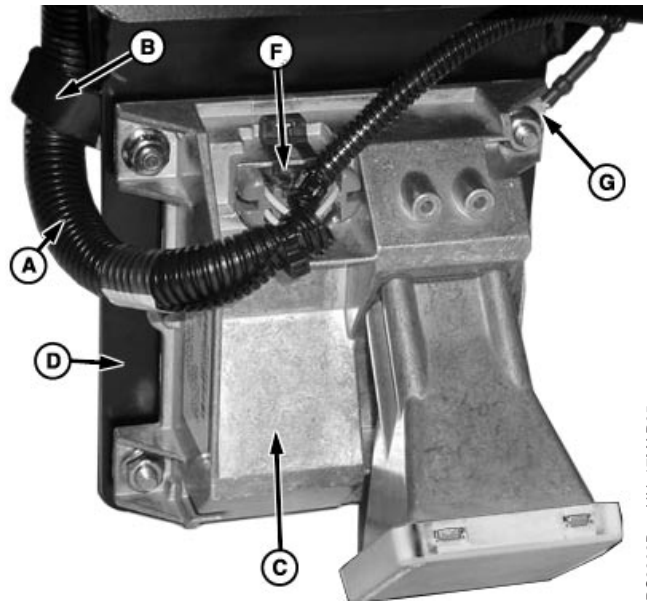

PC8303B -JUN-17MAR05

A—Sensor Harness AN277750
 B—P-Clamp T27550

C—CMFS PF80799
 D—Sensor Bracket

E—Cap Screws, 8 x 25 mm (4
 Used Per Unit)

F—Connector
 G—Ground Wire

13. Route sensor harness (A) through P-clamp (B).
14. Attach CMFS (C) to P-clamp (B) to sensor bracket (D) with 8 x 25 mm cap screws (E) and flange locknuts. Attach sensors on both outer sensor brackets and inner sensor brackets.
15. Attach connector (F) to CMFS.

IMPORTANT: Each sensor must be solidly grounded to chassis to prevent electrostatic discharge problems due to cotton flowing through plastic

duct. Electrostatic discharge can quickly destroy sensor's circuitry if ground connection is done improperly. To ensure proper grounding always mount the CMFS with the nut on the sensor-side of the bracket.

16. Attach ground wire (G) to the top right bolt that attaches sensor to bracket.
17. Make sure full length of harness is securely attach to machine.

OUC6050,00005C1 -19-27AUG04-9/9