



DCY

GreenStar™ Lightbar

OPERATOR'S MANUAL GreenStar Lightbar OMPFP10040 ISSUE G0 (ENGLISH)

CALIFORNIA
Proposition 65 Warning

Diesel engine exhaust and some of its constituents are known to the State of California to cause cancer, birth defects, and other reproductive harm.

If this product contains a gasoline engine:

⚠ WARNING

The engine exhaust from this product contains chemicals known to the State of California to cause cancer, birth defects or other reproductive harm.

The State of California requires the above two warnings.

Additional Proposition 65 Warnings can be found in this manual.

John Deere Werke Zweibrücken

Worldwide Edition
PRINTED IN U.S.A.



OMPFP10040

Introduction

Foreword

WELCOME TO GREENSTAR PRECISION FARMING SYSTEMS offered by John Deere. The GreenStar™ Lightbar is an easy-to-use guidance system.

READ THIS MANUAL carefully to learn how to operate and service your GreenStar™ Lightbar system correctly. Failure to do so could result in personal injury or equipment damage.

THIS MANUAL SHOULD BE CONSIDERED a permanent part of your John Deere GreenStar™ Lightbar system and should remain with the system when you sell it.

RIGHT-HAND AND LEFT-HAND sides are determined by facing in the direction the machine will travel when going forward.

WRITE PRODUCT IDENTIFICATION NUMBERS (P.I.N.) in the Identification Numbers section. Accurately record all the numbers to help in tracing the machine should it be stolen. Your dealer also needs these numbers when you order parts. File the identification numbers in a secure place off the machine.

WARRANTY is provided as part of John Deere's support program for customers who operate and maintain their

GreenStar is a trademark of Deere & Company

equipment as described in this manual. The GreenStar™ Lightbar hardware warranty is explained on the warranty certificate which you should have received from your dealer.

This warranty provides you the assurance that John Deere will back its products where defects appear within the warranty period. In some circumstances, John Deere also provides field improvements, often without charge to the customer, even if the product is out of warranty. Should the GreenStar™ Lightbar system be abused, or modified to change its performance beyond the original factory specifications, the warranty will become void and field improvements may be denied.

IMPORTANT: This manual provides necessary information for appropriate operation of the GreenStar™ Lightbar system.

ENJOY your new GreenStar™ Lightbar system from John Deere.

OUCC002,0002982 -19-18JUN08-1/1

Contents

	Page
Safety	05-1
Installing Lightbar	
Lightbar Guidance System	10-1
General Installation Instructions	10-1
Operating Lightbar Console Suction Cup	10-2
Lightbar System—Standalone Configuration	10-3
Lightbar System—Display Configuration.....	10-4
Operating Lightbar	
Lightbar System Description.....	15-1
Operating Lightbar System.....	15-3
Lightbar System Fuse Protection	15-6
Display Configuration in Companion Mode	
Operating the Lightbar System in Companion Mode.....	20-1
Original GreenStar Display and Lightbar Companion Mode.....	20-1
GS2 1800 Display and Lightbar Companion Mode.....	20-1
GS2 2600 Display and Lightbar Companion Mode.....	20-3
Lightbar Specifications	
Safety Note Regarding the Subsequent Installation of Electrical and Electronic Appliances and/or Components	25-1
EC Declaration of Conformity	25-1
Serial Numbers	
Identification Label.....	30-1
Lightbar Console	30-1

Original Instructions. All information, illustrations and specifications in this manual are based on the latest information available at the time of publication. The right is reserved to make changes at any time without notice.

COPYRIGHT © 2010
DEERE & COMPANY
Moline, Illinois
All rights reserved.
A John Deere ILLUSTRATION © Manual

Safety

Recognize Safety Information

This is a safety-alert symbol. When you see this symbol on your machine or in this manual, be alert to the potential for personal injury.

Follow recommended precautions and safe operating practices.



T81389 —UN—07DEC88

DX,ALERT -19-29SEP98-1/1

Understand Signal Words

A signal word—DANGER, WARNING, or CAUTION—is used with the safety-alert symbol. DANGER identifies the most serious hazards.

DANGER or WARNING safety signs are located near specific hazards. General precautions are listed on CAUTION safety signs. CAUTION also calls attention to safety messages in this manual.



TS187 —19—30SEP88

DX,SIGNAL -19-03MAR93-1/1

Follow Safety Instructions

Carefully read all safety messages in this manual and on your machine safety signs. Keep safety signs in good condition. Replace missing or damaged safety signs. Be sure new equipment components and repair parts include the current safety signs. Replacement safety signs are available from your John Deere dealer.

There can be additional safety information contained on parts and components sourced from suppliers that is not reproduced in this operator's manual.

Learn how to operate the machine and how to use controls properly. Do not let anyone operate without instruction.

Keep your machine in proper working condition. Unauthorized modifications to the machine may impair the function and/or safety and affect machine life.



TS201 —UN—23AUG88

If you do not understand any part of this manual and need assistance, contact your John Deere dealer.

DX,READ -19-16JUN09-1/1

Safety

⚠ CAUTION: Avoid possible injury or death from machinery runaway.

Do not connect auxiliary equipment to starter terminals. If normal circuitry is bypassed by shorting across starter terminals, tractor will start in gear and move.

Stop tractor engine and remove key.

IMPORTANT:

- Do NOT mount Lightbar so that it obstructs operator's field of view.
- Use tie straps and proper routing of harness to avoid trip hazard.
- Do NOT cover warning labels or indicators.



- Install within reach of operator.

TS177 —UN—11JAN89

OUCC002,00029A9 -19-18JUN08-1/1

Operate Guidance Systems Safely

The GreenStar™ Lightbar system is intended to aid the operator in performing field operations more efficiently. The operator is always responsible for machine path. To prevent injury to operator and bystanders:

- Remain alert and pay attention to surrounding environment.

- Turn off or remove the GreenStar™ Lightbar system during road transport. Do not attempt to operate this system on roadways.
- Steer vehicle as necessary to avoid field hazards, bystanders, equipment, or other obstacles.
- Stop operation if poor visibility conditions impair your ability to operate the machine or identify obstacles or bystanders in machine path.

OUCC002,00029AC -19-07JUL08-1/1

Handle Electronic Components and Brackets Safely

Falling while installing or removing electronic components mounted on equipment can cause serious injury. Use a ladder or platform to easily reach each mounting location. Use sturdy and secure footholds and handholds. Do not install or remove components in wet or icy conditions.

If installing or servicing a RTK base station on a tower or other tall structure, use a certified climber.

If installing or servicing a global positioning receiver mast used on an implement, use proper lifting techniques and wear proper protective equipment. The mast is heavy and can be awkward to handle. Two people are required when mounting locations are not accessible from the ground or from a service platform.



TS249 —UN—23AUG88

DX,WW,RECEIVER -19-24AUG10-1/1

Installing Lightbar

Lightbar Guidance System



ZX1044380

ZX1044380—UN—30JUN10

GreenStar™ Lightbar system shows your position in field relative to track that you determine with your first pass through field. Using LEDs on your Lightbar display, you know which way to steer in order to keep your path parallel with your last.

The Lightbar system can be used in a standalone configuration with just a StarFire receiver or can

be used with a GreenStar™ display in conjunction with the GPS receiver (companion mode). Refer to Lightbar System—Standalone Configuration or Lightbar System—Display Configuration in this Section and to Section Display Configuration in Companion Mode.

NOTE: The Lightbar console tilt angle is adjustable.

OUC002,0002DFD -19-30JUN10-1/1

General Installation Instructions

Follow these guidelines to correctly install and maintain the GreenStar™ Lightbar system:

- Install within reach of the operator.
- Do not cover up decals or indicators.
- Do not obstruct operator's view.
- Do not store in direct sunlight.
- Do not direct high-pressure jet on Lightbar.
- Do not use harsh chemicals (such as solvents or gasoline) or unauthorized rubber cleaners and conditioners to clean the cup. Contact your John Deere Dealer.

The GreenStar™ Lightbar suction cup is intended to be attached on the front windshield of tractor.

IMPORTANT: Mistreatment or misuse may damage a suction cup or otherwise create conditions which could cause the suction cup to fail, resulting in an unexpected release.

- Do not allow anything to interfere with free movement of the plunger while the cup is attached. This could prevent the red line from alerting the user of vacuum loss.
- Remove Lightbar and suction cup from windshield when not in use.
- Keep suction cup clean.
- Re-attach suction cup every 24 hours.

NOTE: Read also instructions and cautions contained in the suction cup instruction manual.

OUC002,0002DFE -19-30JUN10-1/1

Operating Lightbar Console Suction Cup

IMPORTANT: Use the cup at temperatures from -18 to 49 °C (0 to 120 °F). Moisture or contaminants can reduce the slip resistance of the cup. The red line indicator (A) may not perform reliably at elevations above 1500 m (5000 ft.).

Read also instructions and cautions contained in the suction cup instruction manual.

The manual pump removes air from between the rubber pad and the windshield contact surface. A red line (A) on the pump plunger (B) serves as a vacuum indicator.

The two release pads (C) allow the cup to disengage completely.

NOTE: A check valve allows the operator to re-pump the cup without removing it from the contact surface.

1. To Attach:

1. Clean the windshield contact surface and, if necessary, the inner face of the suction cup.
2. Position the cup so the red line (A) is visible in case it should appear (loss of vacuum) while the cup is attached.
3. Pump the plunger (B) until the cup attaches completely. Stop pumping as soon as the red line (A) is hidden.
4. Check the plunger (B) frequently to make sure the cup remains securely attached. If the red line (A) appears,



A—Red line
B—Pump plunger

C—Release pad

pump the plunger (B) until the red line (A) is hidden again.

NOTE: Re-attach suction cup every 24 hours.

1. To Release:

1. Hold the Lightbar console with one hand.
2. Pull one of the release tabs (C) until the cup disengages completely.

OUC002,0002DFF -19-30JUN10-1/1

Lightbar System—Standalone Configuration

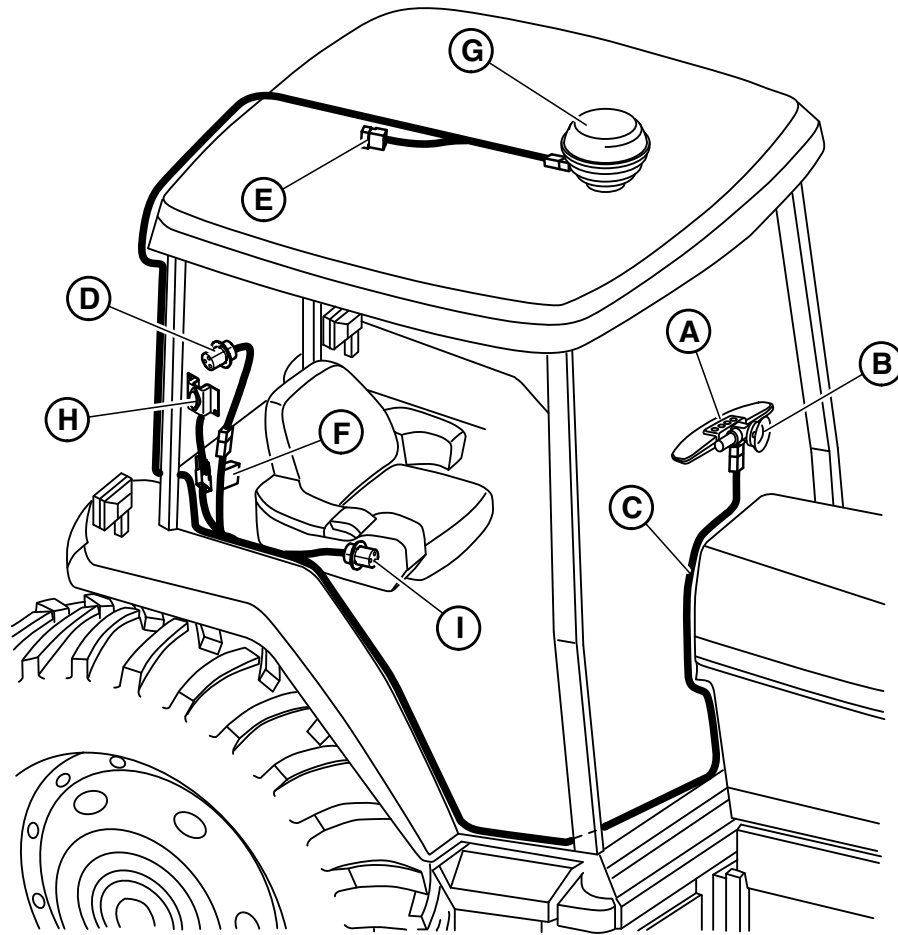

ZX1044378

Standalone Harness Routing

- | | | |
|------------------------|---------------------------------------|---|
| A—Lightbar | D—Power adapter harness (if required) | G—StarFire receiver |
| B—Suction cup | E—CAN Bus active terminator | H—Suppression diode |
| C—Power supply harness | F—Fuse—10A | I—SERVICE ADVISOR™ diagnostic adapter/connector |

NOTE: Connect power adapter harness (D) to convenience outlet power connector.

Use tie straps to fix the harness (C) routing.

OUC002,0002E00 -19-30JUN10-1/1

ZX1044378 —UN—30JUN10

Lightbar System—Display Configuration

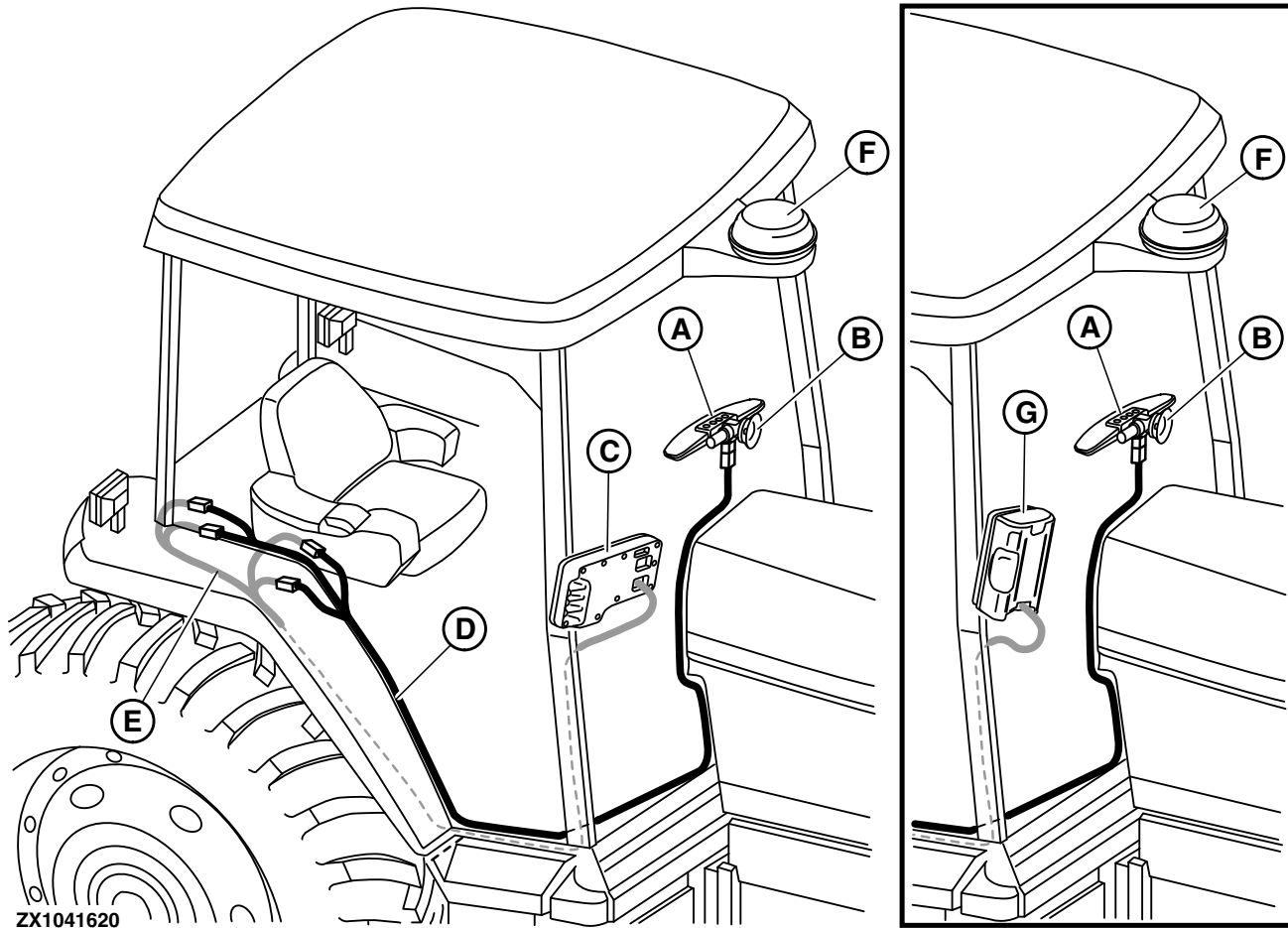

Display Configuration—Without Power Adapter Harness

A—Lightbar
B—Suction cup

C—GS2 1800 Display
D—R.h console harness

E—GreenStar™ Ready Harness
2- and 4- pin connectors
F—StarFire receiver

G—Original GreenStar™ display

NOTE: GS2 1800 (C), GS2 2600 and Original GreenStar™ (G) displays are optional. With the r.h. console harness (D) the Lightbar system can be used in standalone or companion mode (see Section Display Configuration in Companion Mode).

NOTE: See your dealer for adapter harnesses required to install on some self-propelled sprayers.

Continued on next page

OUCC002,0002E01 -19-30JUN10-1/2

ZX1041620 —UN—24JUN08

Installing Lightbar

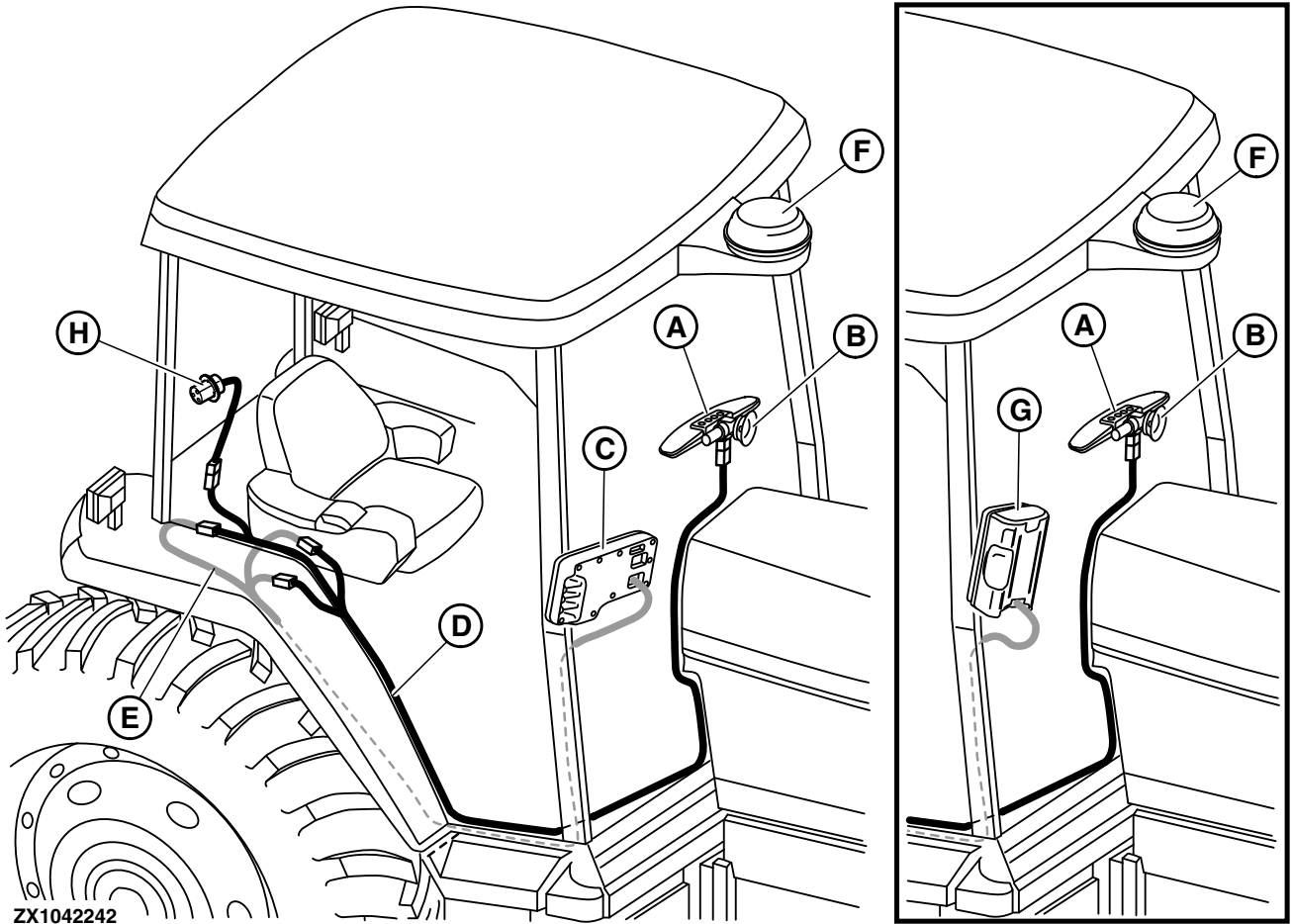

ZX1042242

Display Configuration—With Power Adapter Harness

A—Lightbar
B—Suction cup

C—GS2 1800 Display
D—R.h console harness

E—GreenStar™ Ready Harness
2- and 4- pin connectors
F—StarFire receiver

G—Original GreenStar™ display
H—Power adapter harness

ZX1042242—JUN—07JUL08

OUC002.0002E01 -19-30JUN10-2/2

Operating Lightbar

Lightbar System Description

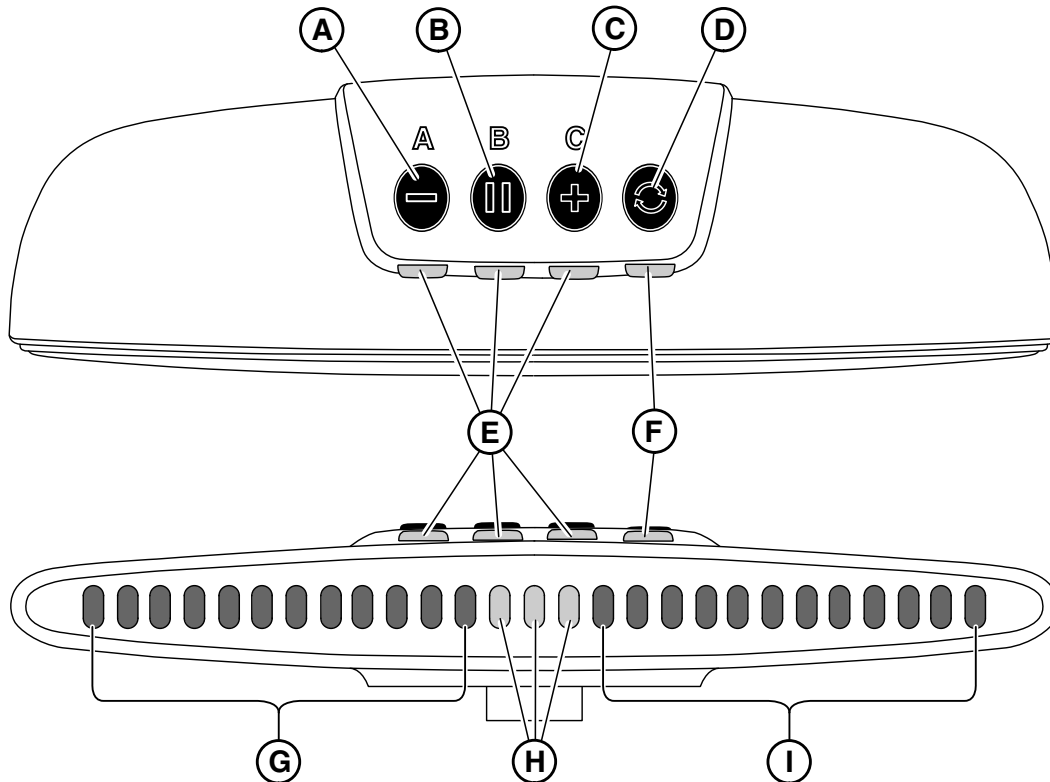

ZX1041592

ZX1041592—UN—16APR08

- | | | |
|---|------------------------------------|---|
| A—Set point A/Decrease LED Brightness/Decrease Spacing Button | D—Mode Button | G—L.h. Offset Tracking/Decrease Tracking Indicator LEDs (Red) |
| B—Set point B/Center Track Button | E—Operator Input Indicator LED | H—Center Tracking Indicator LEDs (Green) |
| C—Set point C/Increase LED Brightness/Increase Spacing Button | F—GPS Signal Quality Indicator LED | I—R.h. Offset Tracking/Increase Tracking Indicator LEDs (Red) |

NOTE: The Lightbar performs a 5 seconds LED test with all LEDs illuminated upon power up.

The Lightbar system is designed to be connected to the vehicle CAN Bus or to be operated as a standalone system and can be used with or without a GreenStar™ display in conjunction with the StarFire GPS receiver (see Lightbar System—Standalone Configuration or Lightbar System—Display Configuration in this Section).

NOTE: Whenever a display is detected on the CAN bus, the Lightbar system will be placed into companion mode. In this mode, the Lightbar buttons are disabled and all guidance setup is performed in the GreenStar™ display. Refer to relevant Display Operator's Manual.

The Lightbar system turns on with the vehicle key switch.

⚠ CAUTION: The Lightbar system **MUST** be turned OFF during road transport. Press and hold Mode Button (D) for 2 seconds to turn off the Lightbar.

As a standalone system, the Lightbar can be operated in three different modes by pressing Mode button (D). Depending on the mode selected, the buttons (A), (B) and (C) will have different functionality (see Operating Lightbar System in this Section):

1. **Run Mode:** Allows the operator to adjust LED brightness by using buttons (A) or (C) or do a center track by using button (B).
2. **Setup Mode:** Allows the operator to setup tracking by using buttons (A), (B) and (C).
3. **Adjust Mode:** Allows the operator to adjust track spacing by using buttons (A) or (C).

Continued on next page

OUC002,0002E03 -19-29JUN10-1/2

IMPORTANT: The Lightbar system checks the GPS signal quality. Either WAAS, EGNOS, SF1, or SF2 is required for Lightbar system to function. Without the required differential quality, no navigation LEDs will be displayed on the lightbar.

A Starfire Configurator Software is available from Stellar Support (<http://stellarsupport.deere.com>) for activating and setting up SF1 and SF2 signals from a laptop. An additional harness is required—Contact your John Deere dealer.

The LED (F) beneath the mode button (D) indicates the GPS signal quality in the following manner:

Green = Good quality—High accuracy.

Amber = Low accuracy.

Amber flashing = Signal available but not sufficient to drive parallel tracking.

Red = no GPS signal available.

Red flashing = no GPS receiver detected.

IMPORTANT: The Lightbar system can still be used when LED (F) glows amber, but accuracy will be lower (reduced GPS signal quality).

IMPORTANT: The tracking LED navigation is possible when steering in forward direction to the desired path only. The Lightbar system does not support the vehicle reverse operation.

At first time boot-up, the factory settings are:

- Track Spacing = 5 m (16 ft 4.8 in.)

Operating Lightbar System

The Lightbar system can be operated under three operating modes.

The **Run Mode** (I) is automatically activated (normal operation) if a valid setup has been performed (Refer to "Operating Lightbar Under Run Mode").

NOTE: If a valid setup has not been performed the Lightbar automatically starts under Setup mode.

Press the button (D) to select the **Setup Mode** (II)—The LED beneath the **A** button is activated to confirm selection of Setup Mode (Refer to "Operating Lightbar Under Setup Mode").

Press the button (D) to select the **Adjust Mode** (III)—The LEDs beneath the **A** and **C** buttons are activated to confirm selection of Adjust Mode (Refer to "Operating Lightbar Under Adjust Mode").

- | | |
|--------------------------|------------------------------------|
| I— Run Operating Mode | III— Adjust Operating Mode |
| II— Setup Operating Mode | D— Operating Mode Selection Button |

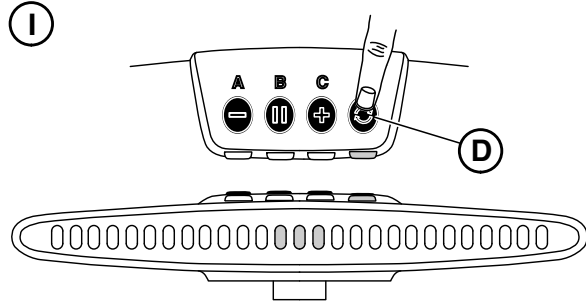

ZX1041593

Run Operating Mode

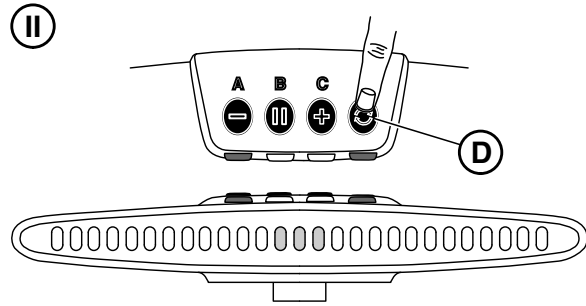

ZX1041601

Setup Operating Mode

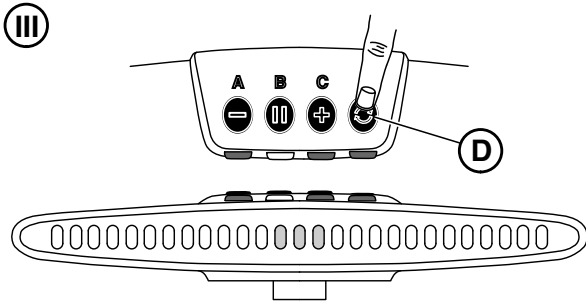

ZX1041602

Adjust Operating Mode

ZX1041593 —UN—16APR08

ZX1041601 —UN—16APR08

ZX1041602 —UN—16APR08

Continued on next page

OUC002,00029B1 -19-07JUL08-1/5

Operating Lightbar Under Run Mode

The Run Mode is automatically activated under normal operation if a valid setup has been performed. To be sure that run mode is activated check that no LEDs beneath the **A**, **B** or **C** buttons are activated. If necessary, press button **(D)** until LEDs beneath buttons **A**, **B** or **C** are all off to access the run mode. Select this operating mode to:

- Increase/decrease the LED brightness by pressing the button **(A)** or **(C)**.
- Do a center track by pressing the button **(B)**.
 - The system activates the center tracking indicator LEDs **(F)**. When driving on track only these LEDs are activated.
 - If a track offset to the right-hand side is detected the system activates the L.h.offset tracking indicator LEDs **(E)** proportionally to the offset detected (about 10 cm (3.93 in.) per LED **(E)** activated). This LED activation informs the operator that he must steer to the left-hand side until all L.h.offset tracking indicator LEDs **(E)** are off.
 - If a track offset to the left-hand side is detected the system activates the R.h.offset tracking indicator LEDs **(G)** proportionally to the offset detected (about 10 cm (3.93 in.) per LED **(G)** activated). This LED activation informs the operator that he must steer to the right-hand side until all R.h.offset tracking indicator LEDs **(G)** are off.

Track Finder Functionality:

To help the operator in finding the track spacing while turning in headland, the system changes to flashing LEDs **(E)** or **(G)** everytime the gauge limit of the lightbar is reached. The flashing frequency indicates the distance from the track:

- A higher frequency means closer to the track.
- A lower frequency means further away from track.

NOTE: Flashing of LEDs starts at a distance from track of 1,3 m (4 ft 3.12 in.) at 10 Hz and changes to 1 Hz at track spacing/2.

- | | |
|---|---|
| A —Decrease LED Brightness Button | E —L.h. Offset Tracking Indicator LEDs (Red) |
| B —Center Track Button | F —Center Tracking Indicator LEDs (Green) |
| C —Increase LED Brightness Button | G —R.h.Offset Tracking Indicator LEDs (Red) |
| D —Operating Mode Selection Button | |

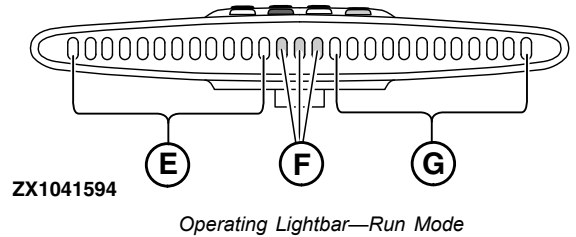
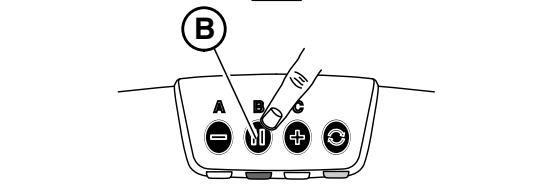
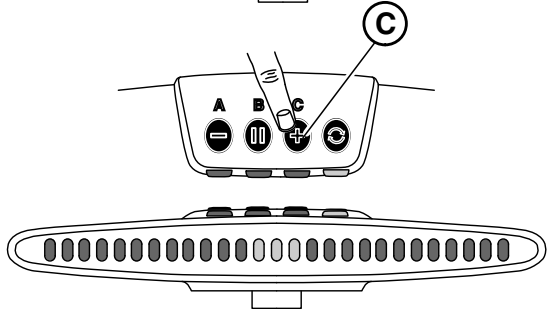
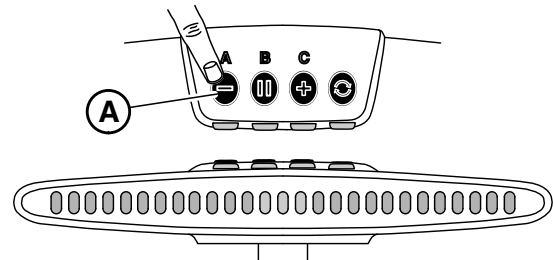
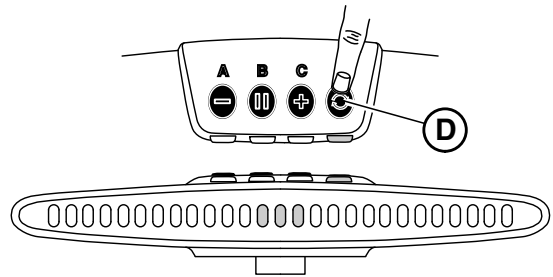

Continued on next page

OUC002,00029B1 -19-07.JUL08-2/5

ZX1041594—UN—16APR08

Operating Lightbar Under Setup Mode

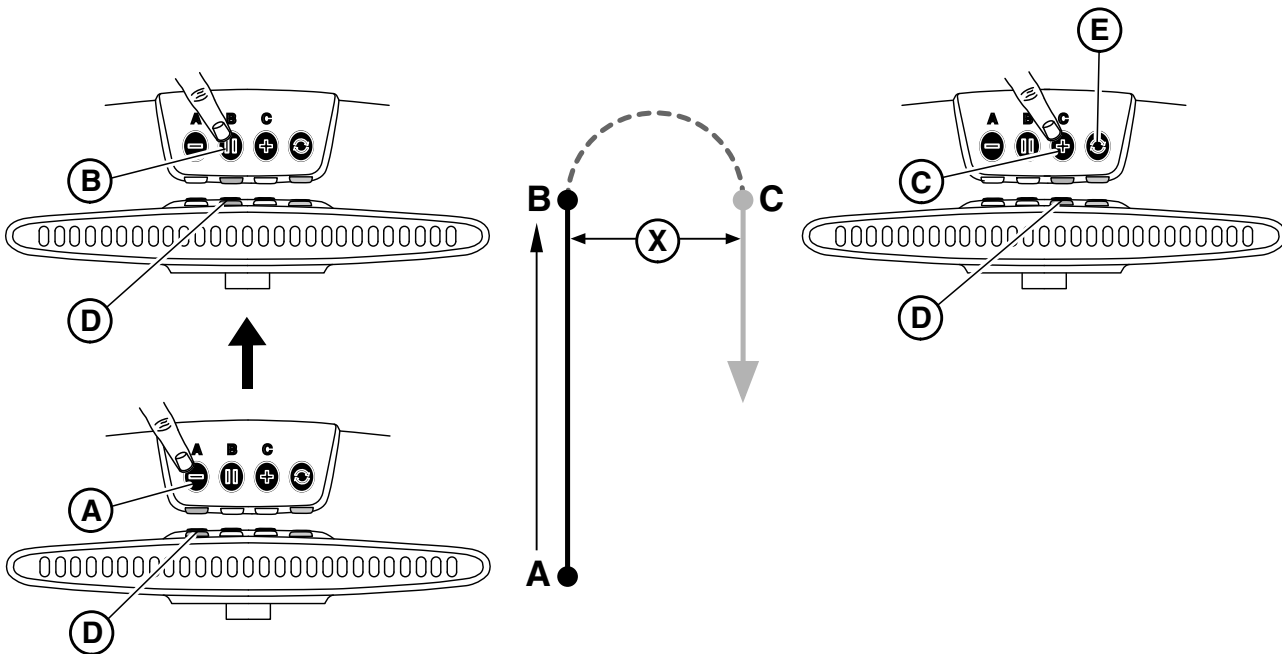

ZX1041595

Operating Lightbar—Setup Mode

- A—Set point A Button
- B—Set point B Button
- C—Set point C Button
- D—Operator Input Indicator LED
- E—Operating Mode Selection Button
- X—Track Spacing

After power up, press button (E) to access setup mode. The LED beneath the **A** button is activated to confirm selection of the Setup Mode. Select this operating mode to:

- **Set a track as initial setup.** The operator needs to define points A, B and C (see illustration). Points A and B are used to calculate the heading and point C is used to calculate the track spacing, which is the distance (X) between the parallel tracks. Setup initial track as follows:

- a. The system turns on the operator input indicator LED beneath the button (A) and waits for the operator input to set **A** point. Press button (A) to start heading calculation.

NOTE: Current position of point A is stored.

- b. The system turns on the operator input indicator LED (flashing) beneath the button (B). The system checks that the operator has driven at least 3 m (9 ft 10 in.) then operator input LED becomes solid. The system waits for the operator input to set **B** point. Press button (B) when point **B** is reached.

NOTE: New A-B line is calculated and stored.

- c. The system turns on the operator input indicator LED (flashing) beneath the button (C). The system checks that the vehicle heading is greater than 90 degrees from A-B line then operator input LED becomes solid. The system waits for the operator input to set **C** point. Press button (C) for less than 2 seconds when point **C** is reached.

NOTE: Vehicle position C and track spacing (X) are calculated and stored. System switches to Run Mode.

NOTE: Pressing button (C) longer than 2 seconds will recall the latest stored track spacing (X). System switches to Run Mode.

- **Recall a track spacing previously set.** Whenever the operator needs to keep his track spacing a new A-B line can be setup and current track spacing (X) recalled by pressing button (C) longer than 2 seconds (see explanation above for initial track setup).

NOTE: During initial track setup procedure, all tracking indicator LEDs are off.

ZX1041595—UN—16APR08

Continued on next page

OUC002,00029B1 -19-07JUL08-3/5

Operating Lightbar

Once the track spacing (X) has been setup: Press button (E) twice to select adjust mode and fine tune track

spacing (X), if necessary. See "Operating Lightbar Under Adjust Mode".

OUCC002.00029B1 -19-07JUL08-4/5

Operating Lightbar Under Adjust Mode

After power up, press button (B) twice to access adjust mode. The LEDs beneath the **A** and **C** buttons are activated to confirm selection of adjust mode. Select this operating mode to fine tune the track spacing:

- The system turns on the operator input indicator LED beneath the buttons (A) and (C) as shown opposite.
- Press button (A) to decrease track spacing. Each tracking indicator LED (D) activation represents 10 cm (3.93 in.) of track spacing decrement.
- Press button (C) to increase track spacing. Each tracking indicator LED (E) activation represents 10 cm (3.93 in.) of track spacing increment.

A—Decrease Spacing Button
B—Operating Mode Selection Button
C—Increase Spacing Button

D—Decrease Tracking Indicator LEDs (Red)
E—Increase Tracking Indicator LEDs (Red)

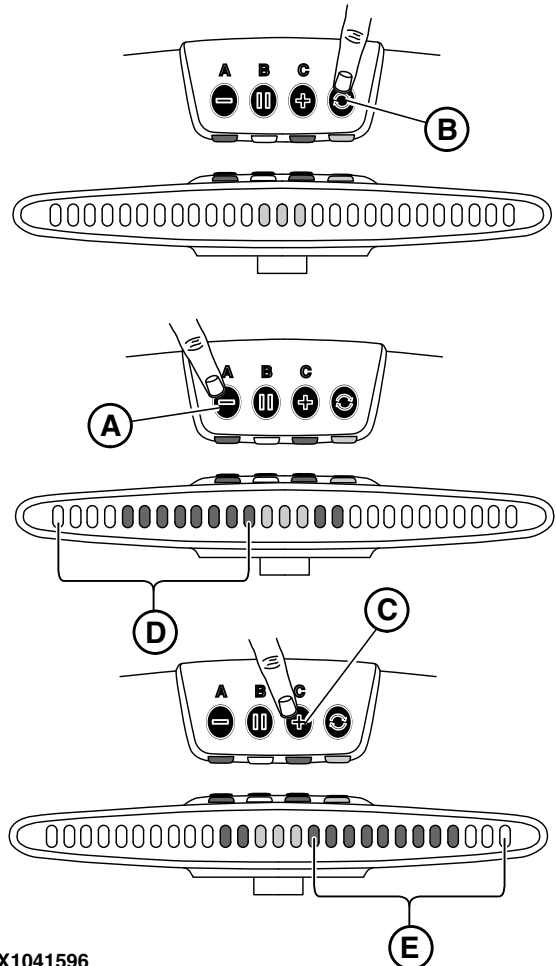

ZX1041596

Operating Lightbar—Adjust Mode

OUCC002.00029B1 -19-07JUL08-5/5

ZX1041596 —UN—05MAY08

Lightbar System Fuse Protection

- **Standalone Configuration:** A 10A fuse (A) located on power supply harness protects the Lightbar system.
- **Display Configuration:** The tractor electrical system protects the Lightbar system. To identify which fuse protects the Lightbar system, refer to the tractor Operator's Manual.

A—Fuse-10 A

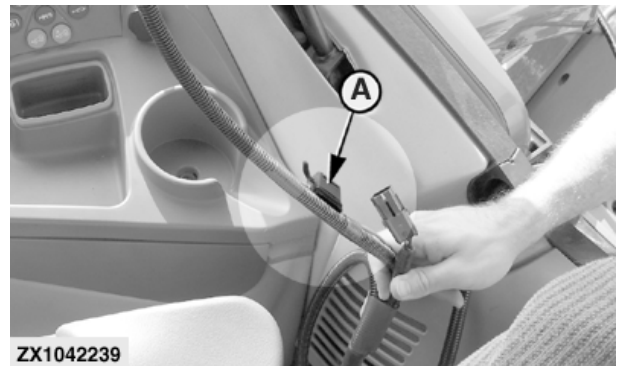

ZX1042239

ZX1042239 —UN—18JUN08

OUCC002.00029A8 -19-24JUN08-1/1

Display Configuration in Companion Mode

Operating the Lightbar System in Companion Mode

The GreenStar Lightbar may be used in companion mode with a GreenStar Display (Original, GS2 1800, or GS2 2600). When both the Lightbar and display are connected to the vehicle CAN bus, the display will automatically recognize the Lightbar and the Lightbar system will be placed into companion mode.

The Lightbar buttons and Mode LEDs will be disabled and all guidance setup is performed in the GreenStar display. Refer to the relevant display Operator's Manual.

Benefits of companion mode are:

- Exact implement width and track spacing can be entered.
- 'Offset' implements can be utilized.
- StarFire™ GPS receiver diagnostics.
- Coverage mapping (GS2 displays only).

NOTE: The GreenStar Display must be updated with the latest software.

OUCC002,0002E07 -19-30JUN10-1/1

Original GreenStar Display and Lightbar Companion Mode

In companion configuration with an Original GreenStar Display, there is NO setup page specifically for the GreenStar Lightbar.

The Guidance Track setup is done on the display. The Lightbar tracking LEDs will light up in increments of 10 cm

(4 in.). These increments do NOT match the distance at which the Tracking Tones are activated.

The brightness of the Lightbar LEDs is synchronized with the brightness setting of the display.

OUCC002,0002E06 -19-30JUN10-1/1

GS2 1800 Display and Lightbar Companion Mode

In companion configuration with a GS2 1800 Display, two additional Lightbar Settings pages are available on the display for configuring the Lightbar.

The first Lightbar Settings page allows the user to change the Step Size and Steer Direction of both the Lightbar and Path Accuracy Indicator on the display's Guidance map.

The second Lightbar Settings page allows the user to adjust the Lightbar LED brightness independently of the display.

The third Lightbar Settings page allows the user to mount the Lightbar console upside down and keep the Steer Direction consistent with the Path Accuracy Indicator on the display.

On GS2 1800 display, select Menu >> GreenStar Main >> Settings >> Guidance Settings >> **Lightbar Settings**.

Step Size – is used to set the value of off-track distance each box on the Path Accuracy Indicator represents. If the display is used with GreenStar Lightbar, the Step Size will also set the value of off-track distance that each light represents on the Lightbar.

Steer Towards Direction – When this option is selected, the lights illuminated to the left on the Path Accuracy Indicator and GreenStar Lightbar mean the vehicle must be steered to the left to align with the guidance track.

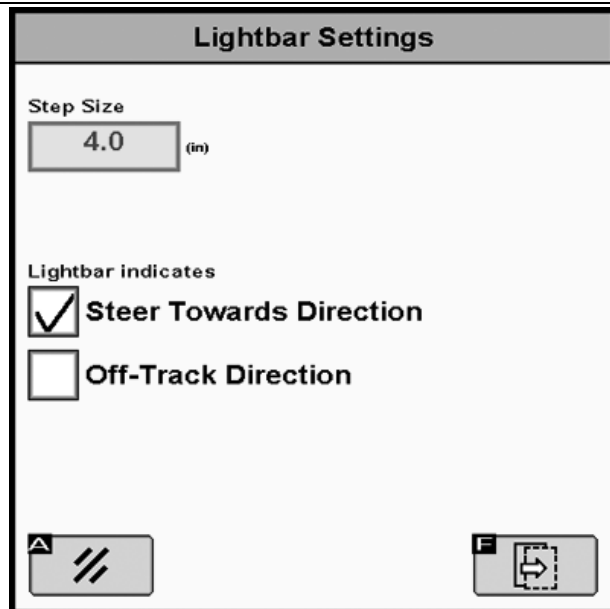

PC10857NI—UN—27APR09

Off Track Direction – When this option is selected, the lights illuminated to the left on the Path Accuracy Indicator and GreenStar Lightbar mean the vehicle must be steered to the right to align with the guidance track.

Continued on next page

OUCC002,0002E08 -19-30JUN10-1/3

External Lightbar On – Check the box to turn ON the GreenStar Lightbar.

Adjust Brightness of GreenStar Lightbar – The brightness of the external GreenStar Lightbar will synchronize with the brightness setting of the display. This setting is available to adjust the GreenStar Lightbar brightness relative to the brightness of the display.

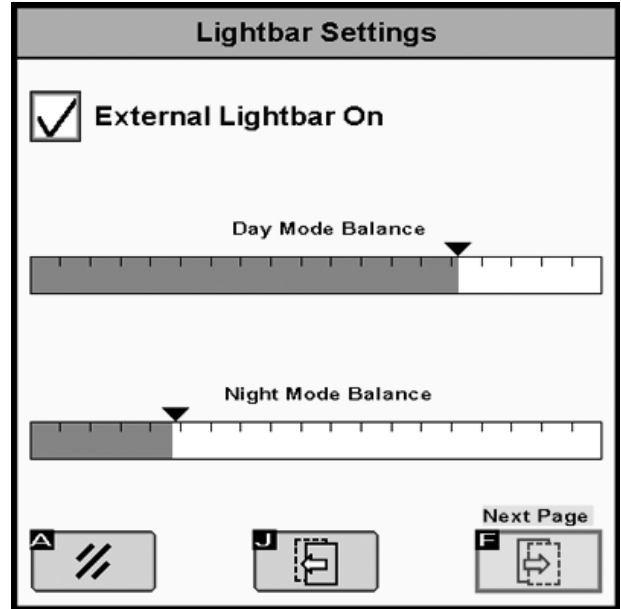

PC10857NJ —UN—27APR09

OUC002,0002E08 -19-30JUN10-2/3

Configure the Mounting Direction of the Lightbar –

This setting allows the GreenStar Lightbar console to be mounted upside down. When this page is open, half of the lights on the GreenStar Lightbar will light up if it is installed correctly. Simply check the box for the direction that the lights appear.

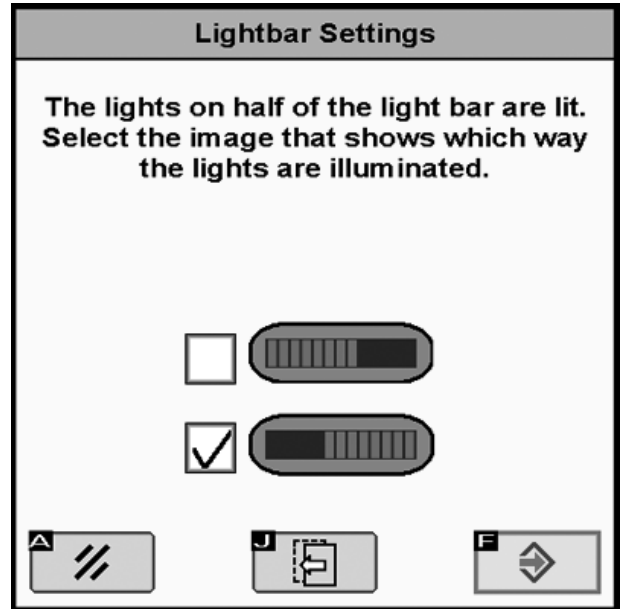

PC10857NK —UN—27APR09

OUC002,0002E08 -19-30JUN10-3/3

GS2 2600 Display and Lightbar Companion Mode

In companion configuration with a GS2 2600 Display, there is NO setup page specifically for the GreenStar Lightbar.

The Guidance Track setup is done on the display.

The Lightbar tracking LED step size synchronizes with the step size of the Path Accuracy Indicator on the display's Guidance map.

The step size is set in General Guidance Settings. On GS2 2600 display, select Menu >> GreenStar 2 Pro >> Guidance >> Guidance Settings >> **General Settings** >> Next.

Step Size – is used to set the value of off-track distance each box on the Path Accuracy Indicator represents. If the display is used with an external GreenStar Lightbar, the Step Size will also set the value of off-track distance that each light represents on the Lightbar.

The brightness of the Lightbar LEDs is synchronized with the brightness setting of the display.

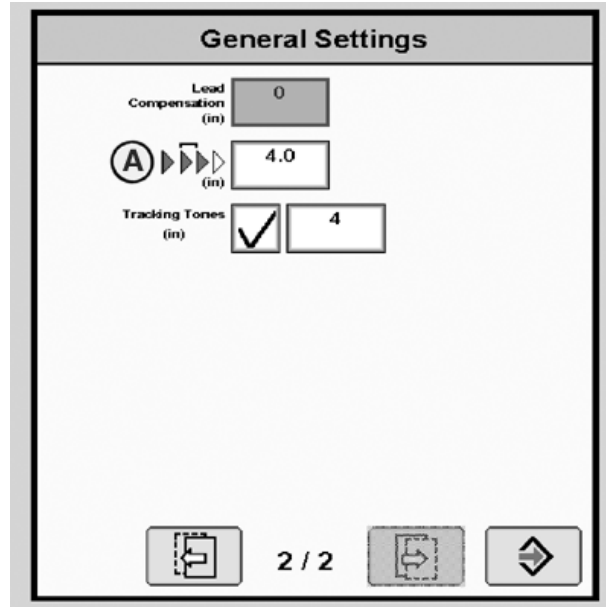

A—Step Size

OUCC002,0002E09 -19-30JUN10-1/1

Lightbar Specifications

Safety Note Regarding the Subsequent Installation of Electrical and Electronic Appliances and/or Components

The machine is equipped with electronic components whose function may be influenced by electromagnetic radiation from other appliances. Such influences may be hazardous, so take the following safety instructions into account:

If electrical and electronic appliances are subsequently installed on the machine and connected to the onboard system, the user must verify whether the installation affects the electronics or other components. This applies particularly to:

- Personal Computer
- GPS (Global Positioning System) receiver

In particular, subsequently installed electrical/electronic components must comply with the relevant edition of EMC Directive 89/336/EEC, and be CE marked.

Wiring, installation and maximum permissible current supply must be as stated in the installation instructions of the machine manufacturer.

ZX,OMSPFH,EMV -19-02DEC96-1/1

EC Declaration of Conformity

Deere & Company
Moline, Illinois U.S.A

The undersigned hereby declares that:

Product: Lightbar System

fulfills all relevant provisions and essential requirements of the following directives:

DIRECTIVE	NUMBER	CERTIFICATION METHOD
Electromagnetic Compatibility Directive	2004/108/EC	Self-certified, per Annex II of the Directive

Name and address of the person in the European Community authorized to compile the technical construction file:

Henning Oppermann
Deere & Company European Office
John Deere Strasse 70
D-68163 Mannheim, Germany
EUConformity@johndeere.com

Place of declaration: Urbandale, Iowa U.S.A

Date of declaration: 01 May 2008

Manufacturing unit: John Deere Intelligent Solutions Group

Name: John H. Leinart

Title: Engineering Manager, Ag Management Solutions



DXCE01—UN—28APR09

OUC002,0002E04 -19-29JUN10-1/1

Serial Numbers

Identification Label

The letters and numbers on the label identify a component or assembly. All of these characters are needed when ordering parts or identifying the system or component for

any John Deere product support program. Also, they are needed for law enforcement to trace your Lightbar system if it is ever stolen.

For these reasons, accurately record these characters.

OUCC002,00029A6 -19-18JUN08-1/1

Lightbar Console

Label is located underneath console.



OUCC002,00029A7 -19-18JUN08-1/1

Index

	Page
C	
Companion mode	
Display configuration.....	20-1
GS2 1800 display.....	20-1
GS2 2600 display.....	20-3
Original GreenStar display.....	20-1
F	
Fuse protection.....	15-6
G	
Guidance system	
Display configuration.....	10-4
Lightbar.....	10-1
Standalone configuration.....	10-3
I	
Identification label.....	30-1
Installation instructions.....	10-1
Installing Lightbar	
Display configuration.....	10-4
General instructions.....	10-1
Guidance system.....	10-1
Standalone configuration.....	10-3
Suction cup.....	10-2
L	
LEDs Description.....	15-1
O	
Operating Lightbar	
Adjust mode.....	15-3
Adjust track spacing.....	15-3
Companion mode.....	20-1, 20-3
Display configuration in companion mode.....	20-1
Fuse protection.....	15-6
Recall a track spacing.....	15-3
Run mode.....	15-3
Set a track.....	15-3
Setup mode.....	15-3
Suction cup.....	10-2
S	
Serial numbers	
Console.....	30-1
Identification label.....	30-1
Suction cup.....	10-2
System Description.....	15-1

John Deere Service Keeps You On The Job

John Deere Parts

We help minimize downtime by putting genuine John Deere parts in your hands in a hurry.

That's why we maintain a large and varied inventory—to stay a jump ahead of your needs.



TS100 —UN—23AUG88

DX,IBC,A -19-04JUN90-1/1

The Right Tools

Precision tools and testing equipment enable our Service Department to locate and correct troubles quickly . . . to save you time and money.



TS101 —UN—23AUG88

DX,IBC,B -19-04JUN90-1/1

Well-Trained Technicians

School is never out for John Deere service technicians.

Training schools are held regularly to be sure our personnel know your equipment and how to maintain it.

Result?

Experience you can count on!



TS102 —UN—23AUG88

DX,IBC,C -19-04JUN90-1/1

Prompt Service

Our goal is to provide prompt, efficient care when you want it and where you want it.

We can make repairs at your place or at ours, depending on the circumstances: see us, depend on us.

JOHN DEERE SERVICE SUPERIORITY: We'll be around when you need us.



TS103 —UN—23AUG88

DX,IBC,D -19-04JUN90-1/1

