



DCY

# John Deere AutoTrac™ Controller—Reichhardt™

## OPERATOR'S MANUAL

### John Deere AutoTrac™ Controller—Reichhardt™

OMPFP11368 ISSUE H1 (ENGLISH)

#### CALIFORNIA

#### Proposition 65 Warning

Diesel engine exhaust and some of its constituents are known to the State of California to cause cancer, birth defects, and other reproductive harm.

If this product contains a gasoline engine:

#### **⚠ WARNING**

The engine exhaust from this product contains chemicals known to the State of California to cause cancer, birth defects or other reproductive harm.

The State of California requires the above two warnings.

Additional Proposition 65 Warnings can be found in this manual.

**John Deere Ag Management Solutions**

Worldwide Edition  
PRINTED IN U.S.A.



OMPFP11368

# Introduction

## **www.StellarSupport.com**

*NOTE: Product functionality may not be fully represented in this document due to product changes occurring after the time of printing. Read the latest Operator's Manual and Quick Reference Guide prior to operation. To obtain a copy, see your dealer or visit [www.StellarSupport.com](http://www.StellarSupport.com)*

OUO6050,0000FB1 -19-10AUG10-1/1

## **Foreword**

This AutoTrac Controller Operator's Manual is to be used with the Guidance Operator's Manual.

**READ BOTH MANUALS** carefully to learn how to operate and service your system correctly. Failure to do so could

result in personal injury or equipment damage. These manuals may also be available in other languages. (See your John Deere dealer to order.)

JS56696,0000A39 -19-14JUN11-1/1





# Safety

## Recognize Safety Information

This is a safety-alert symbol. When you see this symbol on your machine or in this manual, be alert to the potential for personal injury.

Follow recommended precautions and safe operating practices.



T81388 —UN—07DEC88

DX,ALERT -19-29SEP98-1/1

## Understand Signal Words

A signal word—DANGER, WARNING, or CAUTION—is used with the safety-alert symbol. DANGER identifies the most serious hazards.

DANGER or WARNING safety signs are located near specific hazards. General precautions are listed on CAUTION safety signs. CAUTION also calls attention to safety messages in this manual.



**▲ WARNING**

**▲ CAUTION**

TS187 —19—30SEP88

DX,SIGNAL -19-03MAR93-1/1

## Follow Safety Instructions

Carefully read all safety messages in this manual and on your machine safety signs. Keep safety signs in good condition. Replace missing or damaged safety signs. Be sure new equipment components and repair parts include the current safety signs. Replacement safety signs are available from your John Deere dealer.

There can be additional safety information contained on parts and components sourced from suppliers that is not reproduced in this operator's manual.

Learn how to operate the machine and how to use controls properly. Do not let anyone operate without instruction.

Keep your machine in proper working condition. Unauthorized modifications to the machine may impair the function and/or safety and affect machine life.



TS201 —UN—23AUG88

If you do not understand any part of this manual and need assistance, contact your John Deere dealer.

DX,READ -19-16JUN09-1/1

### Practice Safe Maintenance

Understand service procedure before doing work. Keep area clean and dry.

Never lubricate, service, or adjust machine while it is moving. Keep hands, feet, and clothing from power-driven parts. Disengage all power and operate controls to relieve pressure. Lower equipment to the ground. Stop the engine. Remove the key. Allow machine to cool.

Securely support any machine elements that must be raised for service work.

Keep all parts in good condition and properly installed. Fix damage immediately. Replace worn or broken parts. Remove any buildup of grease, oil, or debris.

On self-propelled equipment, disconnect battery ground cable (-) before making adjustments on electrical systems or welding on machine.

On towed implements, disconnect wiring harnesses from tractor before servicing electrical system components or welding on machine.



TS218 —UN—23AUG88

DX,SERV -19-17FEB99-1/1

### Handle Electronic Components and Brackets Safely

Falling while installing or removing electronic components mounted on equipment can cause serious injury. Use a ladder or platform to easily reach each mounting location. Use sturdy and secure footholds and handholds. Do not install or remove components in wet or icy conditions.

If installing or servicing a RTK base station on a tower or other tall structure, use a certified climber.

If installing or servicing a global positioning receiver mast used on an implement, use proper lifting techniques and wear proper protective equipment. The mast is heavy and can be awkward to handle. Two people are required when mounting locations are not accessible from the ground or from a service platform.



TS249 —UN—23AUG88

DX,WW,RECEIVER -19-24AUG10-1/1

### Use Seat Belt Properly

Use a seat belt when you operate with a roll-over protective structure (ROPS) or cab to minimize chance of injury from an accident such as an overturn.

Do not use a seat belt if operating without a ROPS or cab.

Replace entire seat belt if mounting hardware, buckle, belt, or retractor show signs of damage.

Inspect seat belt and mounting hardware at least once a year. Look for signs of loose hardware or belt damage, such as cuts, fraying, extreme or unusual wear, discoloration, or abrasion. Replace only with replacement parts approved for your machine. See your John Deere dealer.

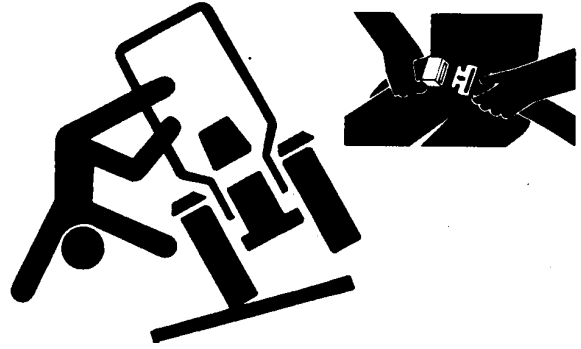

TSS205—JUN—23AUG88

DX,ROPS1 -19-29OCT07-1/1

### Operate Guidance Systems Safely

Do not use guidance systems on roadways. Always turn off (disable) guidance systems before entering a roadway. Do not attempt to turn on (activate) a guidance system while transporting on a roadway.

Guidance systems are intended to aid the operator in performing field operations more efficiently. The operator is always responsible for the machine path.

Guidance Systems include any application that automates vehicle steering. This includes, but may not be limited to, AutoTrac, iGuide, iTEC Pro, ATU, and RowSense.

To prevent injury to the operator and bystanders:

- Never get on or off a moving vehicle.
- Verify the machine, implement, and guidance system are set up correctly. If using iTEC Pro, verify accurate boundaries have been defined.
- Remain alert and pay attention to the surrounding environment.
- Take control of the steering wheel, when necessary, to avoid field hazards, bystanders, equipment, or other obstacles.
- Stop operation if poor visibility conditions impair your ability to operate the machine or identify people or obstacles in the machine path.
- Consider field conditions, visibility, and vehicle configuration when selecting vehicle speed.

JS56696,0000970 -19-10MAY11-1/1

### Use AutoTrac Controller on Approved Vehicles

Use AutoTrac Controller only on Approved Vehicles—see StellarSupport.Deere.com for list of approved vehicles

When activity monitor is selected, AutoTrac Controller looks for operator activity every seven minutes. Operator

will receive a time-out warning 15 seconds before AutoTrac deactivates. Pressing the resume will reset activity monitor timer.

JS56696,0000615 -19-14JUN11-1/1

# Safety Signs

## Automatic Guidance System Detected

This message occurs during startup on vehicles with AutoTrac installed.

The master switch removes power from the EH Valve to prevent AutoTrac from being unintentionally activated. The master switch is intended for use on roadways or when the operator does not want AutoTrac able to be activated.

Ensure AutoTrac is disabled by turning the Master Switch to the OFF position.

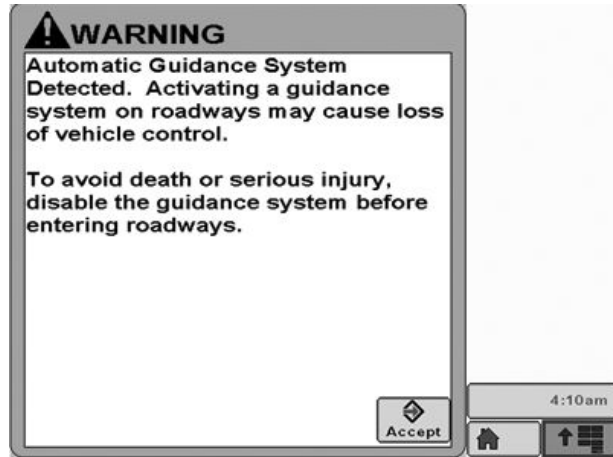

Automatic Guidance

PC13157—19—17FEB11

JS56696,0000A3B -19-14JUN11-1/1

# AutoTrac Controller

## AutoTrac Accuracy

**IMPORTANT: The John Deere AutoTrac system relies on the GPS system operated by the government of the United States, which is solely responsible for its accuracy and maintenance. The system is subject to changes that could affect accuracy and performance of all GPS equipment.**

The overall AutoTrac system accuracy is dependent upon many variables. The equation looks like:

AutoTrac System Accuracy = Signal accuracy + Vehicle Setup + Implement Setup + Field/Soil Conditions.

It is very important to remember:

- Receiver has to go through a warm-up period after starting.
- Vehicle is setup properly (ballasted according to vehicle operator manual, etc.)

- Implement is setup to run properly (wear parts such as shanks, shovels, and sweeps are in good working condition and correctly spaced).
- Understand how field/soil conditions affect system (loose soil requires more steering than firm soil, but firm soil can cause uneven draft loads).

**IMPORTANT: Although AutoTrac system can be activated when SF2 (or SF1 if using AutoTrac SF1 activation) correction signal is confirmed, system accuracy may continue to increase after powering up system.**

AutoTrac SF2 activation will operate on a SF1, SF2, or RTK signal.

AutoTrac SF1 activation will operate on a SF1 signal only.

CF86321.00002B7 -19-17MAY11-1/1

## General Information

All operators must be familiar with AutoTrac system and operating characteristics prior to operation. Operator must know the make of the AutoTrac controller installed on their machine prior to operation. The following is a suggested procedure for operator to become familiar with system:

1. Read and understand Operators Manual for GreenStar Guidance—Parallel Tracking and AutoTrac Assisted Steering Systems.
2. Choose an open area free of hazards (ditches, buildings, etc.).
3. Set Track Spacing to 92.0 meters (300 ft).
4. Set a Track 0 (A—B Line).

*NOTE: Operate vehicle at a speed you are comfortable, recommend less than 8 km/h (5 mph).*

5. Enable AutoTrac on display by turning Steer ON.
6. Press Resume switch to activate AutoTrac. (See Activating system later in this section).
7. After driving a short distance, then turn steering wheel to turn vehicle off track to deactivate AutoTrac. (See Deactivating System later in this section).
8. Practice Activating AutoTrac at different distances before and after crossing track and at different angles. Increase and decrease speeds to simulate different operating conditions.
9. Reduce Track Spacing to acquire multiple tracks and continue practicing activating AutoTrac at different angles and varying speeds to understand how AutoTrac behaves under different conditions.

Always be prepared to resume manual control if AutoTrac does not perform expected maneuvers or machine course must be changed to avoid injury or property damage. Operator can regain manual steering by turning steering wheel or Disabling AutoTrac by turning Steer off on display. It is recommended practice to be as close as possible to desired track prior to activating AutoTrac. This will ensure correct track and direction are acquired.

The AutoTrac basic system is intended to be used as an assistance tool to mechanical markers on planters. Operator must evaluate overall system accuracy to determine specific field operations where assisted steering may be used. This evaluation is necessary because accuracy required for various field operations may differ depending on farming operation. Because AutoTrac uses StarFire differential correction network along with Global Positioning System (GPS), slight shifts in position may occur over time.

To operate AutoTrac operator must set track 0 (similar to parallel tracking) and all tracks are drawn parallel to track 0 using track spacing.

The AutoTrac system operating status can exist at four levels: INSTALLED, CONFIGURED, ENABLED, and ACTIVATED.

After enabling AutoTrac (see Enabling AutoTrac), AutoTrac is activated by pressing resume switch on armrest (see Activating AutoTrac). To return to manual steering, operator must deactivate system (see Deactivating System).

If required track can be shifted left, right or centered using shift track feature on display. (See Shift Track).

CF86321.00002B8 -19-17MAY11-1/1

## AutoTrac Settings

- A—View Tab
- B—Guidance Settings Tab
- C—Shift Track Settings
- D—Tracking Mode
- E—Implement Guidance Mode
- F—General Settings
- G—Curve Track Settings
- H—AutoTrac Advanced Settings
- I—Lightbar Settings

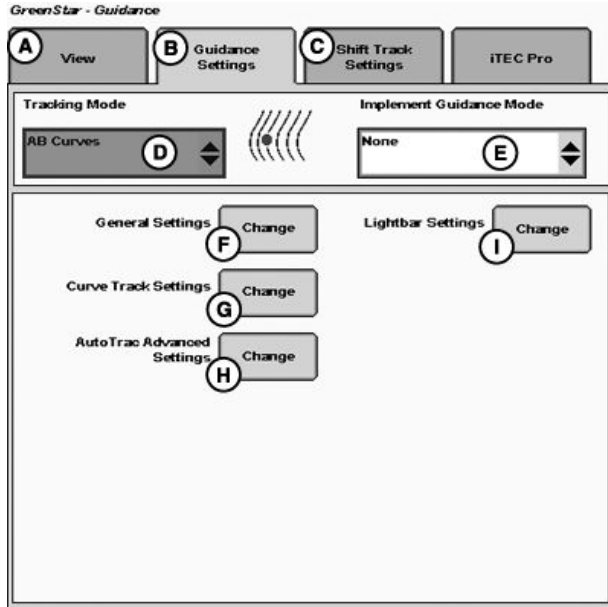

Guidance Settings

CF86321,00002B9 -19-17MAY11-1/1

PC13709 —UN—13MAY11

## Activity Monitor

*NOTE: Activity Monitor will only operate if the seat switch is not operational or not installed on the machine.*

### Operator Detection Timeout

The system has not detected any recent operator activity. AutoTrac will deactivate in: 15 seconds.

Press the Resume Switch or acknowledge this alarm to prevent deactivation.

The Activity Monitor will monitor the status of the operator by requiring the operator to provide input to the display every 7 minutes.

To reset the Activity Monitor, push the resume switch or click the Enter button on the pop-up screen.

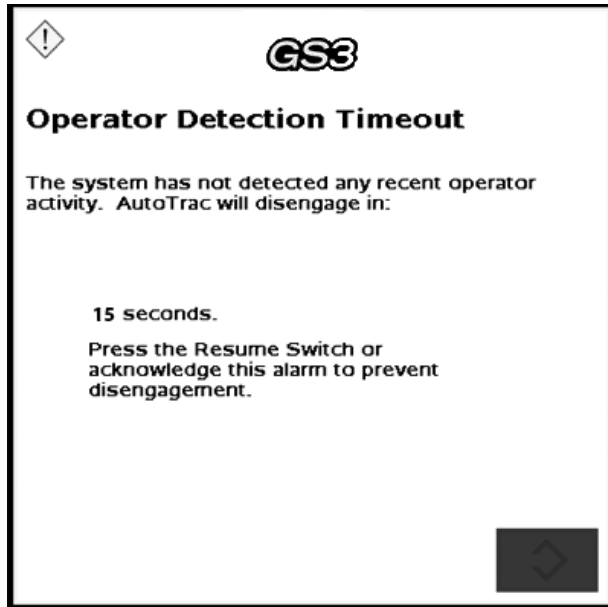

Operator Detection Timeout

BA31779,0000232 -19-20JUL11-1/1

PC13872 —UN—20JUL11

# AutoTrac Controller Troubleshooting

## AutoTrac Controller

Symptom	Problem	Solution
<b>AutoTrac Controller won't activate. AutoTrac will not resume.</b>	Stop Code encountered	See list of stop codes to find issue
<b>AutoTrac Controller does not appear on INFO or SETUP screens</b>	System not recognizing AutoTrac Controller on CAN bus line	Ensure AutoTrac Controller is connected to GreenStar Harness and receiving power  Check for blown fuses in AutoTrac Controller wiring harness
<b>Direction can not be determined</b>	Old TCM Software	Update TCM Software to newest software (Version 1.08 or greater)
	No differential Correction	Establish differential correction
	No GPS	Establish signal
	AutoTrac Controller did not establish direction correctly	Drive forward at a speed greater than 1.6 km/h (1 mph) and turn steering wheel greater than 45 degrees in one direction
<b>Tractor acquires guidance line but tracks 25 to 518 cm (10 to 204 in.) to right or left of line.</b>	AutoTrac Controller has encountered a bad wheel angle sensor calibration and has an incorrect wheel angle sensor bias.	Recalibrate wheel angle sensor and reacquire line to ensure problem is corrected.

## Direction Change Toggle

If the direction of travel is determined to be incorrect, Select the View Tab (A) then select Direction Change Toggle Button (B) to change the displayed direction of travel.

A—View Tab

B—Direction Change Toggle Button

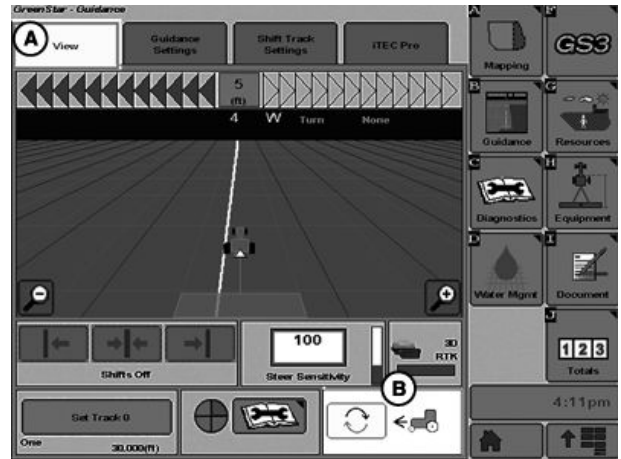

Home Screen

CF86321,000035D -19-23MAY11-1/1

PC13566 —UN—04MAY11

## Diagnostic Readings

### GreenStar Deluxe - Diagnostic Readings

Read the latest Operator Manual prior to operation. To obtain a copy, see your dealer or visit [www.StellarSupport.com](http://www.StellarSupport.com).

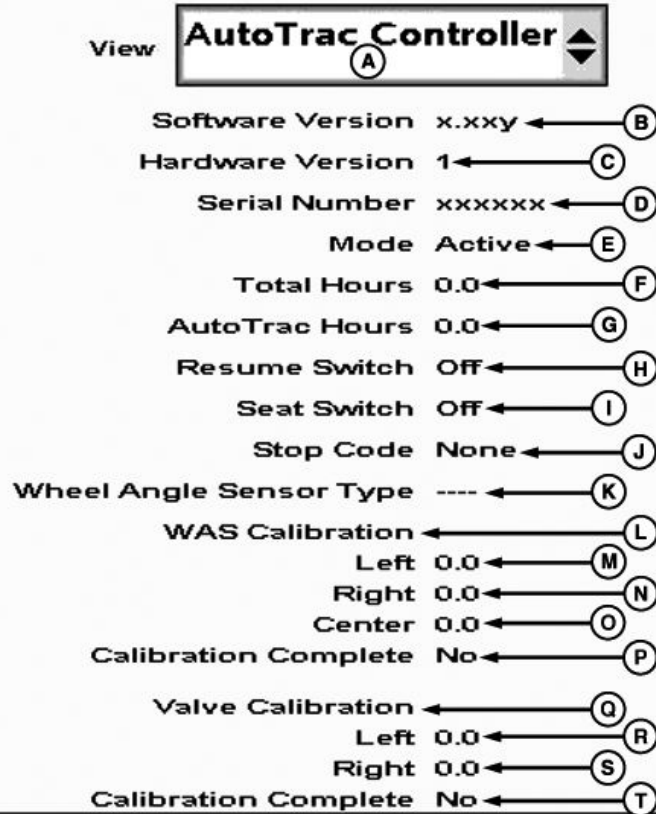

GreenStar Diagnostic Readings

A—View Drop-Down Menu  
 B—Software Version  
 C—Hardware Part Number  
 D—Serial Number  
 E—Mode Status

F—Total Hours  
 G—AutoTrac Hours  
 H—Resume Switch Status  
 I—Seat Switch Status  
 J—Stop Code

K—Wheel Angle Sensor Type  
 L—WAS Calibration  
 M—Left WAS Calibration Number  
 N—Right WAS Calibration Number  
 O—Center WAS Calibration Number

P—WAS Calibration Complete Status  
 Q—Valve Calibration  
 R—Left Valve Calibration Number  
 S—Right Valve Calibration Number  
 T—Valve Calibration Complete Status

Read the latest Operator Manual prior to operation. To obtain a copy, see your dealer or visit [www.StellarSupport.com](http://www.StellarSupport.com).

PC13826—JUN—28JUN11

CF86321,000035E -19-28JUN11-1/1

## Stop Codes

Stop Code	Description	Solution
None	Nothing has been checked yet	
Steering Wheel	Steering wheel has moved to deactivate AutoTrac	Press resume switch to re-activate AutoTrac
Too Slow	Vehicle speed too slow to use AutoTrac	Increase speed over 0.5 km/h (0.3 mph)
Too Fast	Vehicle Speed too high to use AutoTrac	Reduce Speed below platform limit Tractor - 30 km/h (18.6 mph) Sprayer - 37 km/h (23 mph) Harvester - 22 km/h (13.7 mph) Reverse speed on all machines – 10 km/h (6 mph)
Unknown Direction	Unknown direction	Drive forward greater than 1.6 km/h (1 mph) and turn steering wheel greater than 45°
Track Changed	Track number changed	Align vehicle on desired track and press resume
Lost Dual GPS	SF1, SF2, or RTK signal was lost	Establish signal
Steer Control Fault	A steering control fault severe enough to disable AutoTrac	Cycle tractor power
OK	Last state upgrade was successful	
PT Turned Off	Tracking not turned on.	Turn tracking on in Setup - Tracking
Heading Error	Heading error is out of range.	Align tractor within heading limit (80° of track)
Lateral Error	Lateral error is out of range.	Align tractor within lateral limit (40% of track spacing)
No Operator	Operator presence switch is open.	Operator in seat or press resume for activity monitor to reset time
No TCM	Either no TCM present or TCM is turned off.	Turn TCM on, or install TCM
Voltage Unstable	Voltage Too Low	Check harnessing
Reverse Timeout	Reverse Timeout (greater than 45 seconds)	Cycle direction forward before resuming in reverse
0 Speed Timeout	0 Speed Timeout	Increase speed over 0.5 km/h (0.3 mph)
Curvature	Curve Track radius tighter than AutoTrac will allow	Manually drive through tight radius curves
Tracking on Line	Vehicle is driving on line	
Acquiring Line	Vehicle is acquiring line	

DK01672,00000DC -19-23JUN11-1/1

# AutoTrac Controller—Reichardt

## AutoTrac Controller— Reichardt Calibration

From the Main Menu select AutoTrac Controller.

**IMPORTANT: John Deere 2600 Display will not operate with AutoTrac Controller—Reichardt™**

**A**—AutoTrac Controller Button

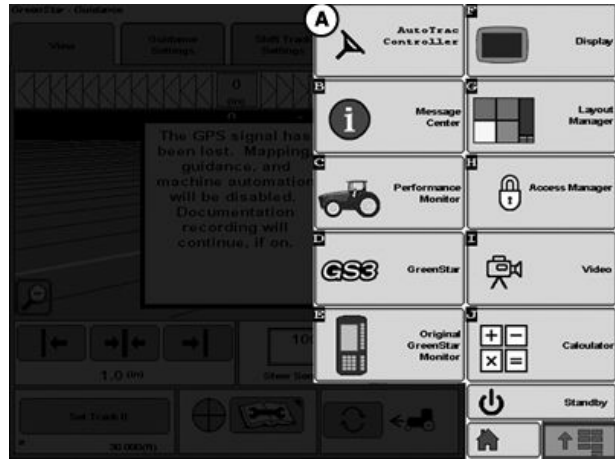

AutoTrac Controller Button

PC13882—UN—20JUL11

BA31779,000021C -19-04AUG11-1/17

The Reichardt Welcome Screen will appear.

On the Reichardt Welcome Screen select the Main Menu Softkey (A) to view the Main Menu screens.

**A**— Main Menu Softkey



Reichardt Welcome Screen

PC13831—UN—03AUG11

Continued on next page

BA31779,000021C -19-04AUG11-2/17

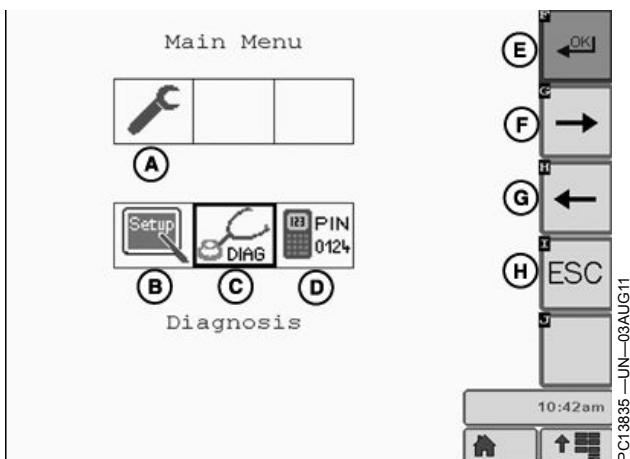

Reichhardt Diagnosis Menu

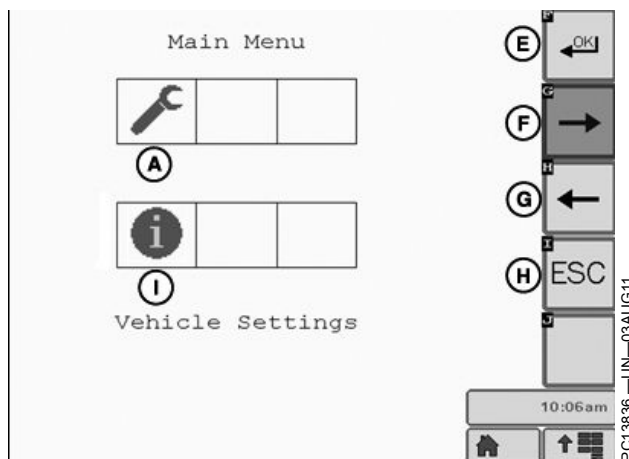

Reichhardt Settings Menu

### Main Menu

Use the Forward (F) and Backward (G) buttons to scroll through the Main Menu pages.

*NOTE: The icon with the bold box around it is the one currently selected.*

- |                     |                          |
|---------------------|--------------------------|
| A—Main Menu Softkey | F—Toggle Forward Softkey |
| B—Setup             | G—Toggle Back Softkey    |
| C—Diagnose Menu     | H—ESC Softkey            |
| D—Pass Code Entry   | I—Info Menu              |
| E—OK Softkey        | J—Machine Health Test    |

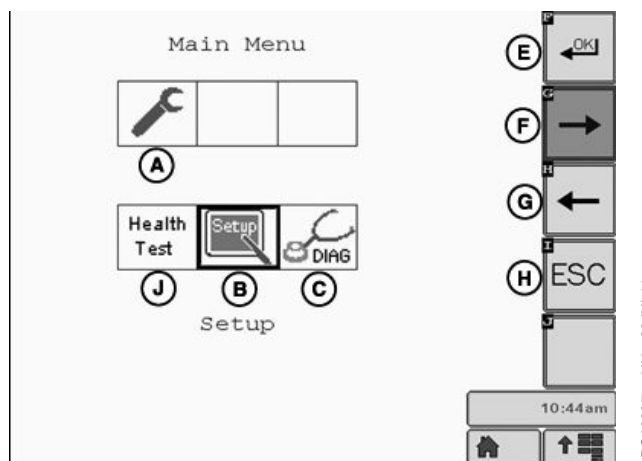

Reichhardt Setup Menu

Continued on next page

BA31779,000021C -19-04AUG11-3/17

### Entering Setup Menu

Enter Setup menu by selecting setup and pressing OK to start setup.

- Drive tractor slowly at full throttle for approximately 2 to 5 minutes to bring hydraulic fluid to operating temperature before beginning calibration procedure.
- Calibration procedure will require a large, open, level surface to complete the required steps.
- Calibration procedure must be completed prior to using AutoTrac for the first time.
- Calibration procedure must be complete with a passing status prior to using AutoTrac. If a passing status is not achieved then AutoTrac will not work.

**IMPORTANT: Read all instructions before calibrating the AutoTrac Controller**

**AutoTrac calibration should be completed without an implement connected to the tractor to avoid damage to the tractor or implement.**

*NOTE: At any time during calibration, the operator may take control of the system by pressing the Stop or ESC button.*

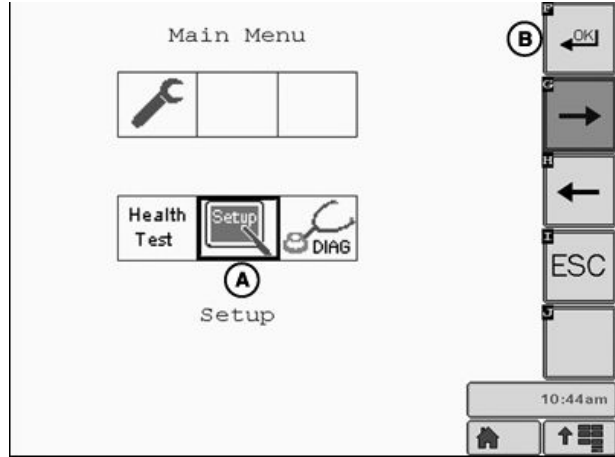

A—Setup

B—OK Softkey

PC13873—UN—28JUL11

BA31779,000021C -19-04AUG11-4/17

### Vehicle Code

Prior to starting the setup, make sure resume switch on Reichhardt main harness is in "ON" position.

To begin the calibration select the SETUP icon from the Main Menu and enter the Vehicle Code that corresponds to the current tractor model.

1. Press OK (B).
2. Change vehicle Code using the +/- (C and D) softkeys.

*NOTE: codes are located in the Installation Manual. For further questions contact your JD Dealer*

3. Press and hold OK until audible sound is heard (0.5 seconds aprox.).

As each step is completed, press and hold OK softkey until audible sound is heard to proceed automatically to the next step.

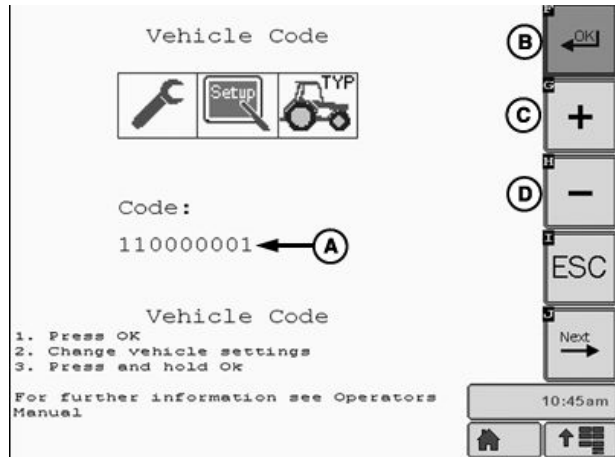

A—Vehicle Code  
B—OK Softkey

C—Increase  
D—Decrease

PC13839—UN—20JUL11

Continued on next page

BA31779,000021C -19-04AUG11-5/17

### Wheelbase

1. Enter Wheelbase (A) of tractor using the +/- (C and D) softkeys.
2. Press and hold OK to save.

*NOTE: Use a tape measure to accurately determine machine wheelbase.*

A—Wheelbase Value                      C—Increase Softkey  
 B—OK Softkey                              D—Decrease Softkey

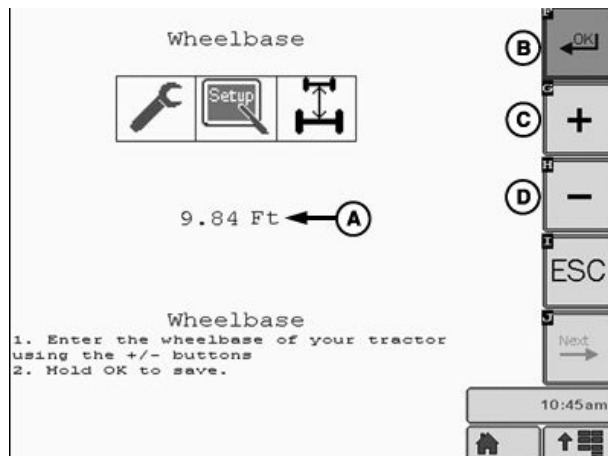

PC13840 —UN—20JUL11

BA31779,000021C -19-04AUG11-6/17

**CAUTION:** Front wheels will turn automatically.  
 To prevent injury, ensure there are no bystanders in the path of the vehicle.

Press the ESC Button to cancel calibration

A—OK Softkey                              B—ESC Softkey

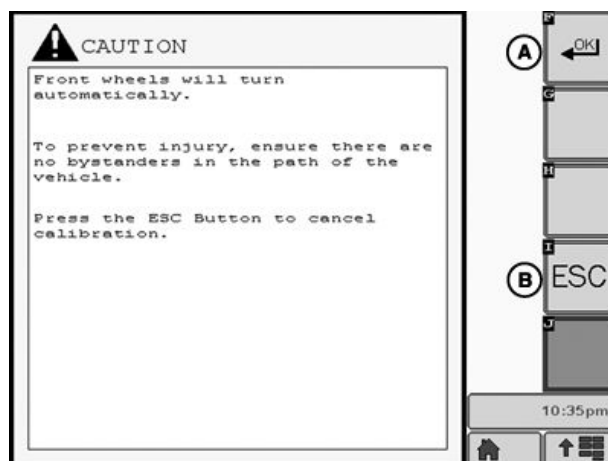

PC13870 —UN—20JUL11

BA31779,000021C -19-04AUG11-7/17

### Current Controller

1. Press and hold Start (A) to begin.

*NOTE: Once calibration is started, the "START" button changes to "STOP" button until calibration is completed.*

A—Start Softkey

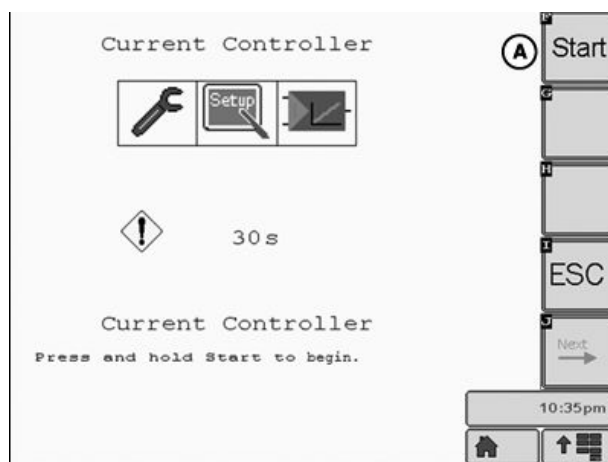

PC13871 —UN—20JUL11

Continued on next page

BA31779,000021C -19-04AUG11-8/17

### Valve Deadband Left

Valve Deadband Left commands the wheels to turn left at the lowest command. Valve Deadband Left will need to be adjusted to the lowest setting that gives smooth wheel motion. Use the +/- softkeys (B and C) to adjust.

1. Press Start (A).
2. Adjust to the lowest setting that gives smooth wheel motion using the +/- softkeys (B and C).
3. Press and hold OK to save.

**NOTE:** Once the test is started, the Start button will change to an OK button.

*The only way to stop wheel movement is by pressing the ESC softkey (D). Manually steering the wheel will allow operator to control steering. Once steering wheel is released, it will begin to steer to the right or left again.*

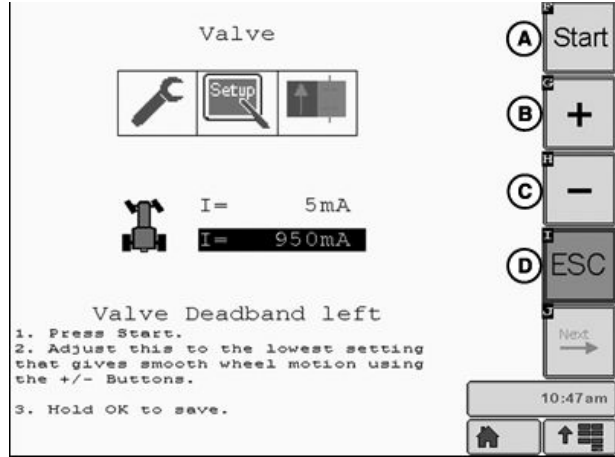

A—Start Softkey  
B—Increase Softkey

C—Decrease Softkey  
D—ESC Softkey

BA31779,000021C -19-04AUG11-9/17

### Valve Deadband Right

Valve Deadband Right commands the wheels to turn right at the lowest command. Valve Deadband Right will need to be adjusted to the lowest setting that gives smooth wheel motion. Use the +/- softkeys (B and C) to adjust.

1. Press Start (A).
2. Adjust to the lowest setting that gives smooth wheel motion using the +/- softkeys (B and C).
3. Press and hold OK to save.

A—Start Softkey  
B—Increase Softkey

C—Decrease Softkey



Continued on next page

BA31779,000021C -19-04AUG11-10/17

### Wheel Angle Sensor Left Calibration

1. Turn wheels to the left stop and hold.
2. Press and hold OK (A) to save.

*NOTE: It is important that the wheels are turned all of the way to the left and right during the WAS Calibration or undesired AutoTrac operation may occur.*

A—OK Softkey

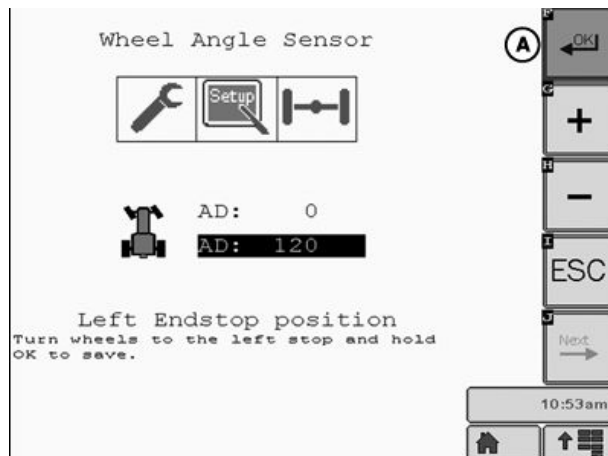

PC13844—UN—20JUL11

BA31779,000021C -19-04AUG11-11/17

### Wheel Angle Sensor Center Calibration

1. Align wheels straight and hold.
2. Press and hold OK (A) to save.

*NOTE: An accurate center WAS calibration is critical to have desired AutoTrac operation. Driving a short distance looking down the center of the hood and turning your wheels so that you drive straight to a fixed point on the horizon maybe required.*

A—OK Softkey

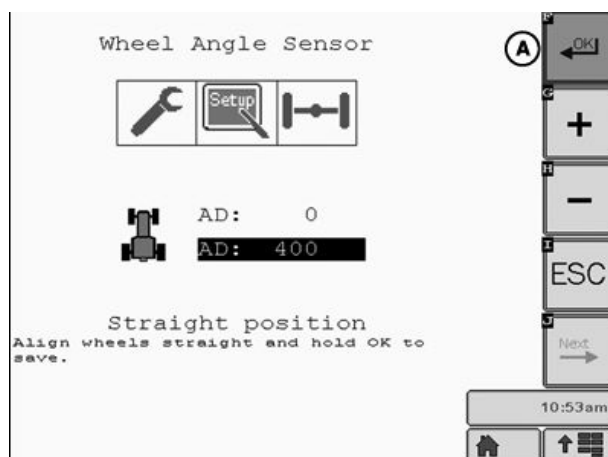

PC13845—UN—20JUL11

BA31779,000021C -19-04AUG11-12/17

### Wheel Angle Sensor Right Calibration

1. Turn wheels to right stop and hold.
2. Press and hold OK (A) to save.

A—OK Softkey



PC13846—UN—20JUL11

Continued on next page

BA31779,000021C -19-04AUG11-13/17

### Pressure Sensor Calibration - Standby Pressure

1. Make sure engine is running.
2. Don't move the steering wheel.
3. Press and hold OK (A) to save.

A—OK Softkey

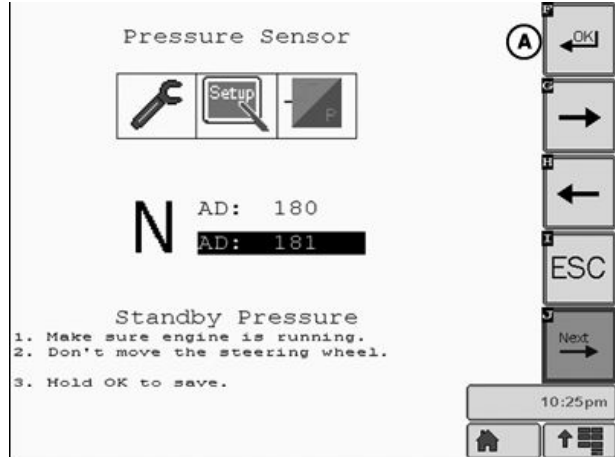

PC13851 —UN—20JUL11

BA31779,000021C -19-04AUG11-14/17

### Tractor Turning Diameter

To determine the machine turning diameter, drive the vehicle in a circle and then measure the distance across the circle from the inside tire tracks.

The Health test functionality can also be used to determine the machine turning diameter by doing the following steps:

1. Navigate to Health Test from the Main Menu.
2. Select Curvature Test (A) and then OK (B).
3. Select Start (D).
4. Drive circles clockwise/counter clockwise until the radius (C) shows a stable value and does not change any longer.
5. Double the value for radius (C) to get the left or right turning diameter.
6. Repeat the steps in the opposite direction to get the other turning diameter.

A—Curvature Test  
B—OK Softkey  
C—Radius

D—Start Softkey  
E—ESC Softkey

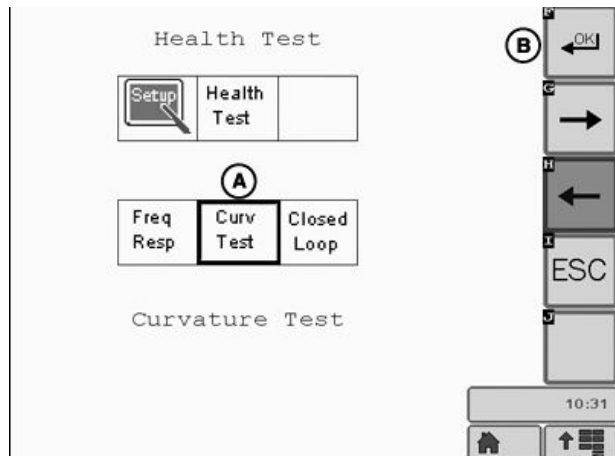

PC13875 —UN—03AUG11

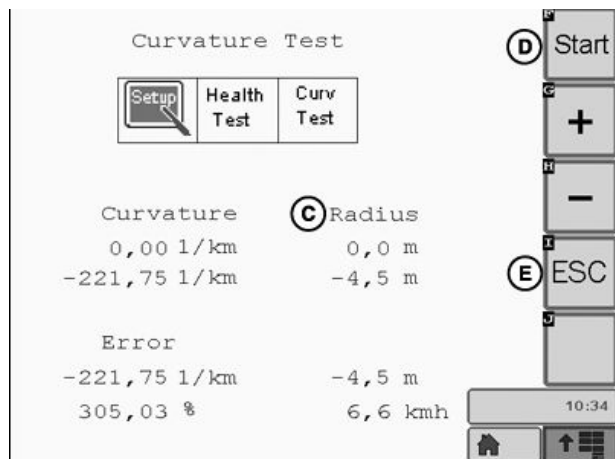

PC13876 —UN—03AUG11

Continued on next page

BA31779,000021C -19-04AUG11-15/17

### Tractor Turning Diameter – Left

1. Enter the tractor's minimum left turning diameter using the +/- softkeys (B and C).
2. Press and hold OK (A) to save.

A—OK  
B—Increase Softkey  
C—Decrease Softkey

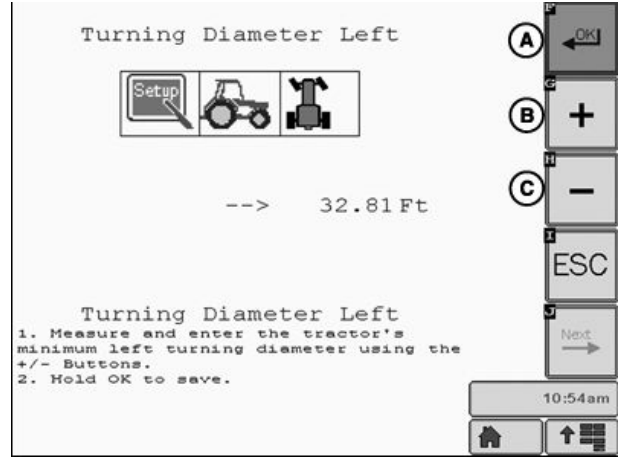

PC13848—UN—20JUL11

BA31779,000021C -19-04AUG11-16/17

### Tractor Turning Diameter – Right

1. Enter the tractor's minimum right turning diameter using the +/- softkeys (B and C).
2. Press and hold OK (A) to save.

A—OK  
B—Increase Softkey  
C—Decrease Softkey

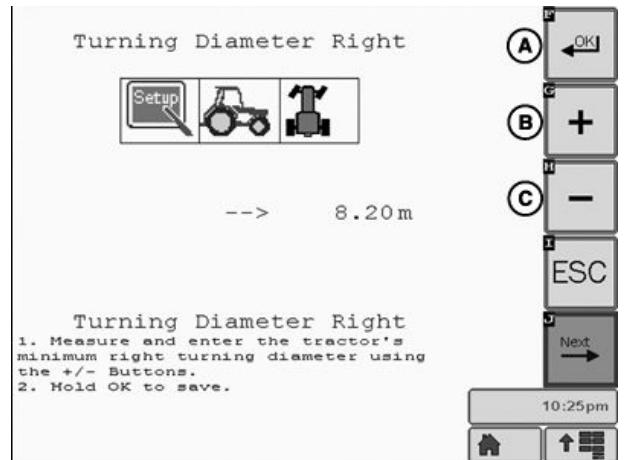

PC13852—UN—20JUL11

BA31779,000021C -19-04AUG11-17/17

### Failed Calibrations

If calibration failure persists, check the Message Center and/or contact your John Deere dealer.

A failed calibration may be the result of:

- Incorrect inputs provided by the operator
- Not enough area to complete calibration without stopping during the calibration step
- Grabbing the steering wheel to avoid obstacles
- Wheel angle sensor not responding
- Valve not responding.
- Machine hardware failure

BA31779,000021D -19-29JUN11-1/1

## Necessary Conditions for Activating AutoTrac

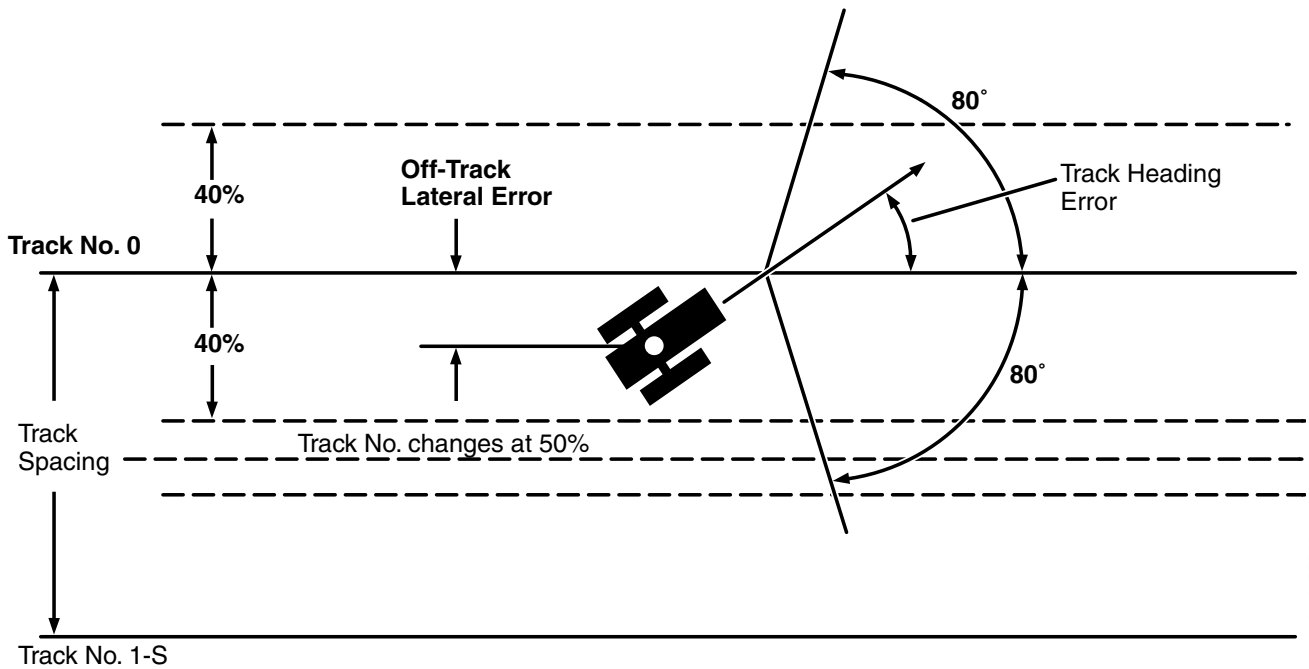

PC7051—19—04FEB02

Once tractor is at end of row operator must turn system to next pass. By turning steering wheel, AutoTrac is deactivated. Operator must turn onto next track.

1. System is enabled (steering ON on RUN screen).
2. The machine is within 40% of track spacing.
3. Track heading is within 80° of track.

AutoTrac can be activated by pressing resume switch only after following conditions are met:

**NOTE:** Calibration procedure must be complete with a passing status prior to using AutoTrac.

BA31779,000021E -19-29JUN11-1/2

Once two pieces of the PIE are achieved, the operator can enable AutoTrac by selecting the Steer On icon.

If two pieces of the PIE can not be achieved, the operator will not be able to activate AutoTrac.

- A diagnostic button is located next to the PIE icon.
- If two pieces of the PIE can not be achieved, select wrench icon to view AutoTrac Diagnostics.

The Diagnostics page will indicate what is needed for each of the four PIE pieces and the status of all requirements.

AutoTrac may not become available until hydraulic temperature has reached pre set level (1 PIE piece only until warm). This issue will not provide any diagnostic code or show in the status menu.

PC11972—UN—09APR09



Steer On icon

PC11971—UN—09APR09



Pie Pieces

PC11973—UN—09APR09



AutoTrac Diagnostics Wrench

BA31779,000021E -19-29JUN11-2/2

## AutoTrac Controller—Reichhardt Diagnostic Addresses

PC8663 —UN—05AUG05



MENU button

### Diagnostic Addresses

Select Diagnostic Address button and a list of controllers will appear and controllers with diagnostic codes are indicated.

PC8655 —UN—05AUG05



MESSAGE CENTER button (With Info Icon)

Individual controllers can be accessed by pressing ENTER button to view codes for that controller.

To view the AutoTrac Controller Reichhardt select ACI.001 Implement from the device drop down menu.

PC8668 —UN—05AUG05

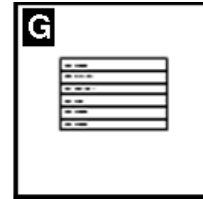

Diagnostic Addresses

Codes can also be displayed for all controllers by selecting SHOW ALL button and pressing ENTER button. Codes can be relayed to a John Deere dealer to assist in diagnosing machine problems.

All diagnostic codes below are specific to AutoTrac Controller—Reichhardt.

Diagnostic Address	Description
001	Recall Trouble Codes
003	ELX Voltage
004	Battery voltage
005	5V Regulator Voltage at the Regulator
008	LS pressure Sensor Voltage
009	LS Pressure Sensor-Measured pressure in kpa
010	WAS/Gyro Sensor Voltage
013	WAS Calibrated Center Voltage
014	WAS Calibrated Full-Left Voltage
015	WAS Calibrated Full-Right Voltage
016	WAS Actual Wheel Angle
019	GPS Speed kph
023	Max Flow Rate Test
025	Closed-loop Step Response Test
031	Adjustable Parameter-Heading Lead
037	AutoTrac Aggressiveness
048	Adjustable Parameter-Inner-Loop Gain
051	Adjustable Parameter-Heading Gain
052	Adjustable Parameter-Curvature Sensitivity
053	Adjustable Parameter-Acquisition Sensitivity
054	Adjustable Parameter-Lateral Gain
056	Auto Trac Hours
060	Auto Trac Exit Code
061	Steer Switch-Resume Switch-Auto Trac State
062	Parallel Tracking-Keycard Present-TCM State
063	Seat/Track Number/GPS Status
065	Lateral Error
067	Heading Error
071	Lateral Error Accumulator
076	Engineering Diagnostics Enable/Disable

Continued on next page

BA31779,000021F -19-08JUL11-1/2

AutoTrac Controller—Reichhardt

Diagnostic Address	Description
077	Actual Curvature
078	Target Curvature
079	Yaw-Rate
080	Inner loop Gain Proportional
081	Inner Loop Gain Integral
082	Inner Loop Gain Derivative
083	Inner Loop Filtered Constant 1
084	Inner Loop Filtered Constant 2
085	Valve Left Gain
086	Valve Right Gain
087	Valve Left Deadband (%)
088	Valve Right Deadband (%)
089	Signal to valve (%)
090	Current draw from valve (Power line) (mA)
091	Pressure Sensor 2 Voltage
092	Pressure Transducer 2 (kPa)
093	Pressure Differential (kPa)
110	Steering Override Setting - SID Disengage Pressure Setting (kPa)
219	Controller Configuration Data Part Number
220	Controller Configuration Data Version Number

BA31779,000021F -19-08JUL11-2/2

## AutoTrac Controller—Reichhardt Diagnostic Trouble Codes

Select TROUBLE CODES button, a list of controllers will appear and controllers with diagnostic codes are indicated.

Individual controllers can be accessed by pressing ENTER button to view codes for that controller.

Codes can also be displayed for all controllers by selecting SHOW ALL button and pressing ENTER button. Codes can be relayed to a John Deere dealer to assist in diagnosing machine problems.

PC8663 —UN—05AUG05



MENU button

PC8655 —UN—05AUG05



MESSAGE CENTER button (With Info Icon)

PC8669 —UN—05AUG05



TROUBLE CODES softkey

SPN	FMI	Description
168	3	Steering Controller unswitched supply voltage (cc# 182) out of range high
168	4	Steering Controller unswitched supply voltage (cc# 182) out of range low
232	9	Loss of StarFire Differential Status Message (PGN 65535/0x53)
517	9	GPS Speed Message Missing
628	12	Indicates control unit Steering Controller being reprogrammed (boot block generated). Reprogram control unit Steering Controller. Replace control unit Steering Controller if condition persists.
630	13	Indicates incomplete calibration of steering valve. Wheel Angle Sensor calibration incomplete. AutoTrac will remain disabled until successful calibration of system.
1504	9	Operator out of seat during AutoTrac
1504	14	Operator out of seat during AutoTrac
1504	31	Operator out of seat during AutoTrac - within 2 to 7s
3509	3	Indicates sensor supply voltage (cc# 733) for steering wheel pressure sensor and/or wheel angle position sensor out of range high.
3509	4	Indicates sensor supply voltage (cc# 733) for steering wheel pressure sensor and/or wheel angle position sensor out of range low.
3509	5	Steering Wheel Position Sensor 1 Circuit Current Low
3509	6	Steering Wheel Position Sensor 1 Circuit Current High
1807	5	Steering Wheel Angle
1807	6	Steering Wheel Angle
520431	5	Isolation Shutoff Valve Circuit Current Low
520431	6	Isolation Shutoff Valve Circuit Current High
522385	1	Indicates that the AutoTrac Controller ON/OFF switch on vehicle is not ON. Switch AutoTrac master switch to ON position.
522387	7	Indicates control unit Steering Controller not receiving wheel angle position sensor signal.
522390	9	Abnormal Update Rate
522394	9	TCM Messages Missing
523698	9	IVS Display Message Missing
523767	2	AutoTrac Resume Switch Circuits Conflict
523795	2	Indicates steering valve orientation incorrect. Check steering valve right/left circuit codes switched.
523795	11	Indicates steering valve deadbands inconsistent
523795	13	The deadband is out of range.
523795	12	EH Valve or harness fault
523824	5	Controller - Not in FMEA

Continued on next page

BA31779,0000220 -19-29JUN11-1/2

*AutoTrac Controller—Reichhardt*

<b>SPN</b>	<b>FMI</b>	<b>Description</b>
523824	6	Controller - Not in FMEA
523826	0	Wheel Angle Sensor Primary Signal High
523826	1	Wheel Angle Sensor Primary Signal Low
523826	2	Steering Controller Calibration / Wheel Angle Sensor Polarity
523826	7	Wheel Angle Sensor Primary Fault/No Motion
523826	10	Wheel Angle Sensor Fault/No SID Motion
523826	14	Primary and Secondary Wheel Angle Sensor Conflict
524221	9	Vehicle Yaw Rate Message Missing

BA31779,0000220 -19-29JUN11-2/2

# GS2 Display 1800

## Automatic Guidance System Detected

Each time a machine equipped with AutoTrac is started, this screen will appear as a reminder of operator responsibilities when using AutoTrac steering system.

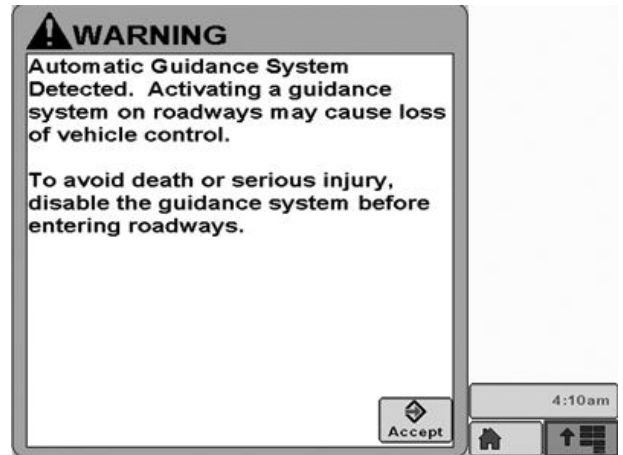

Automatic Guidance

CF86321,000038D -19-01JUN11-1/1

## Enabling System

Press STEER ON/OFF button to toggle between enable/disable AutoTrac.

To enable system, all of the following criteria must be met:

- AutoTrac activation is detected.

- Track 0 has been setup.
- Tracking mode selected.
- Proper operator presence mode selected.
- TCM must be installed and turned on.
- AutoTrac Controller Steering Kit is plugged in.

CF86321,000038E -19-01JUN11-1/1

## Activating System

**CAUTION:** While AutoTrac is activated, operator is responsible for steering at end of path and collision avoidance.

**Do not attempt to turn on (Activate) AutoTrac system while transporting on a roadway.**

After system has been ENABLED, operator must manually change system to ACTIVATED status when steering assistance is desired.

**Press resume switch.** This will initiate assisted steering.

In order to activate system following criteria must be met:

- Vehicle speed is greater than 0.5 km/h (0.3 mph).
- Forward vehicle speed is less than 30 km/h (18.6 mph).
- Reverse vehicle speed is less than 10 km/h (6.0 mph).
- Vehicle within 45 degrees of desired track.
- Operator is seated.
- TCM is on.
- In reverse AutoTrac will remain activated for 45 seconds. After 45 seconds the machine must be put in a forward gear before reverse will activate again.

CF86321,000038F -19-01JUN11-1/1

### GreenStar Run Page

Path Accuracy Indicator - Is a visual indicator of off-track error. The indicator consists of eight boxes on each side of the off-track error box. The boxes will light up indicating the direction the vehicle must be steered to get back on the AB line. Each arrow represents a distance (default is 10 cm (4 in.)). This distance and the steering direction may be defined on the Lightbar Settings Page:

GreenStar Main Page -> Settings -> Guidance Settings -> Lightbar Settings

Off Track Error (A)– Off Track error is numerically displayed in the box. Off Track error will be displayed in cm (inches) up to 99 cm (35 in.). If Off Track error exceeds 99 cm (35 in.), the distance displayed will change to meters (feet).

Track number (B)– Represents the track number the vehicle is guiding on. It also shows the direction that the track is located from the original Track 0 for the field.

Guidance Icon (C)– The icon represents the machine and implement in relative dimensions. The triangle on the machine represents the control point, which is used for guiding the machine and is defined by the machine offset measurements.

GPS Indicator (D)– Indicates what level of accuracy the StarFire receiver is currently operating at (3D, SF2, SF1, RTK). If using a GPS receiver other than a StarFire, the text 3D GPS will be displayed but the indicator bar will not fill.

AutoTrac Status Pie (E)(See AutoTrac section)

*NOTE: Some softkeys only appear when the hardware or functions associated with those buttons are connected or available, such as the AutoTrac controls.*

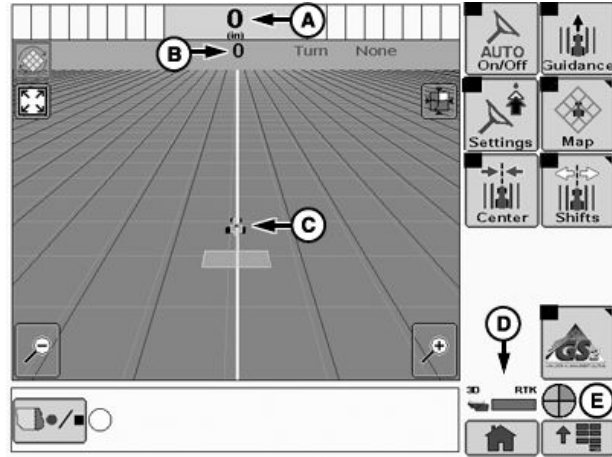

PC13962 —UN—01AUG11

PC10857JN —UN—13APR09



GreenStar Main Page

PC10857JF —UN—13APR09



Settings Button

PC10857KZ —UN—14APR09

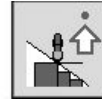

Guidance Settings

A—Off Track Error  
B—Track number  
C—Guidance Icon

D—GPS Indicator  
E—AutoTrac Status Pie

BA31779,000024B -19-01AUG11-1/23

AutoTrac Steer On/Off – Enables and disables AutoTrac

PC13711 —UN—16MAY11



Auto Steer On/Off

Continued on next page

BA31779,000024B -19-01AUG11-2/23

Select the Settings button. This will give the operator the option to increase or decrease the steering sensitivity and Direction Toggle button.

Direction Toggle button can be used to change the direction of the vehicle on the map if it is different than the direction the machine is traveling.

PC13959 —UN—01AUG11



Settings

PC10857LB —UN—14APR09



Increase AutoTrac Steering Sensitivity

PC10857LC —UN—14APR09



Decrease AutoTrac Steering Sensitivity

PC13960 —UN—01AUG11



Direction Toggle

BA31779,000024B -19-01AUG11-3/23

Recording ON/OFF – Turns coverage recording ON and OFF when Manual recording source is selected.

PC10857LD —UN—14APR09



Recording ON/OFF

BA31779,000024B -19-01AUG11-4/23

ShiftTrack – Go to the following Shift Track Controls. Shift Track is used to adjust position of machine left, center, or right of the set track. Shift track can be used to compensate for GPS drift. Drift is inherent to any satellite based, differentially corrected GPS system.

PC10857NC —UN—24SEP09



ShiftTrack

BA31779,000024B -19-01AUG11-5/23

Shift Track Left

PC10857LE —UN—14APR09



Shift Track Left

BA31779,000024B -19-01AUG11-6/23

Shift Track Right

PC10857LF —UN—14APR09



Shift Track Right

Continued on next page

BA31779,000024B -19-01AUG11-7/23

Shift Track Center

PC10857LG —UN—14APR09



*Shift Track Center*

BA31779,000024B -19-01AUG11-8/23

Clear Shifts

PC10857LH —UN—14APR09

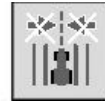

*Clear Shifts*

BA31779,000024B -19-01AUG11-9/23

Back to Run Page Softkeys

PC10857LI —UN—14APR09



*Back button*

BA31779,000024B -19-01AUG11-10/23

Map Controls – Go to the following Map Controls

PC10857LJ —UN—14APR09



*Map Controls*

BA31779,000024B -19-01AUG11-11/23

Toggle Mapping Mode

PC10857LK —UN—14APR09



*Toggle Mapping Mode*

BA31779,000024B -19-01AUG11-12/23

Pan Map Up

PC10857LM —UN—14APR09



*Pan Map Up*

Continued on next page

BA31779,000024B -19-01AUG11-13/23

Pan Map Left

PC10857LN —UN—14APR09



*Pan Map Left*

BA31779,000024B -19-01AUG11-14/23

Pan Map Right

PC10857LO —UN—14APR09

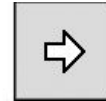

*Pan Map Right*

BA31779,000024B -19-01AUG11-15/23

Pan Map Down

PC10857LP —UN—14APR09



*Pan Map Down*

BA31779,000024B -19-01AUG11-16/23

Toggle Map Size – Selecting this button increases the map to full screen, hiding the softkeys. Select the button again to decrease the maps size and show the softkeys.

PC10857LQ —UN—14APR09



*Toggle Map Size*

BA31779,000024B -19-01AUG11-17/23

Zoom Out

PC10857LR —UN—14APR09



*Zoom Out*

BA31779,000024B -19-01AUG11-18/23

Zoom In

PC10857LR —UN—14APR09



*Zoom In*

Continued on next page

BA31779,000024B -19-01AUG11-19/23

Center Map – Centers the map on the vehicle.

PC10857LT —UN—14APR09

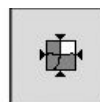

Center Map

BA31779,000024B -19-01AUG11-20/23

Back to Run Page Softkeys

PC10857LI —UN—14APR09



Back Button

BA31779,000024B -19-01AUG11-21/23

Swath Control ON/OFF Toggle

PC10857LU —UN—14APR09

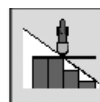

Swath Control ON/OFF Toggle

BA31779,000024B -19-01AUG11-22/23

GreenStar – Go to GreenStar Main Page

PC10857JN —UN—13APR09



GreenStar Main Page

BA31779,000024B -19-01AUG11-23/23

## Enabling AutoTrac

PC13711 —UN—16MAY11

The following criteria must be met for AutoTrac to be enabled:

- Vehicle has an AutoTrac capable steering controller (ACI)
- Valid AutoTrac Activation (26 digit Activation Code)
- Setup Wizard is complete and a guidance track has been created. See the GETTING STARTED section earlier in this manual for Setup Wizard information and see the sections on each Guidance Mode for information on creating guidance tracks.
- Correct StarFire signal level for AutoTrac Activation is selected (SF1, SF2, or RTK) and a valid GPS signal is acquired.
- TCM turned on and TCM message is valid



AutoTrac On/Off

- ACI has no active faults pertaining to the steering function.
- Hydraulic oil warmer than minimum temperature
- Tractors - above 20°C (68°F)
- Forward vehicle speed is less than 30 km/h (18.6 mph)
- Reverse speed is less than 10 km/h (6 mph)

To Enable AutoTrac, select the Steer On/Off softkey located on the Run Page. This softkey will disable AutoTrac if selected again.

CF86321,0000391 -19-01JUN11-1/1

**AutoTrac Status Pie**

PC8832 —UN—25OCT05

The AutoTrac Status Pie is shown at the bottom of the Run Page as a quick diagnostic indicator.

INSTALLED (1/4 of pie)—AutoTrac Steering Controller and all other necessary hardware are installed.



*Installed*

CF86321.0000392 -19-01JUN11-1/4

CONFIGURED (2/4 of pie)—Valid AutoTrac Activation, Tracking Mode has been determined and a valid Track 0 has been established. Correct StarFire signal level for AutoTrac Activation is selected (SF1, SF2, or RTK). Vehicle conditions met.

PC8833 —UN—25OCT05



*Configured*

CF86321.0000392 -19-01JUN11-2/4

ENABLED (3/4 of pie)—Steer On/Off softkey has been selected.

PC8834 —UN—25OCT05

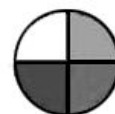

*Enabled*

CF86321.0000392 -19-01JUN11-3/4

ACTIVATED (4/4 of pie with "A")—Resume switch is pressed and AutoTrac is steering the vehicle.

PC8835 —UN—25OCT05



*Activated*

CF86321.0000392 -19-01JUN11-4/4

## Reactivating AutoTrac on Next Pass

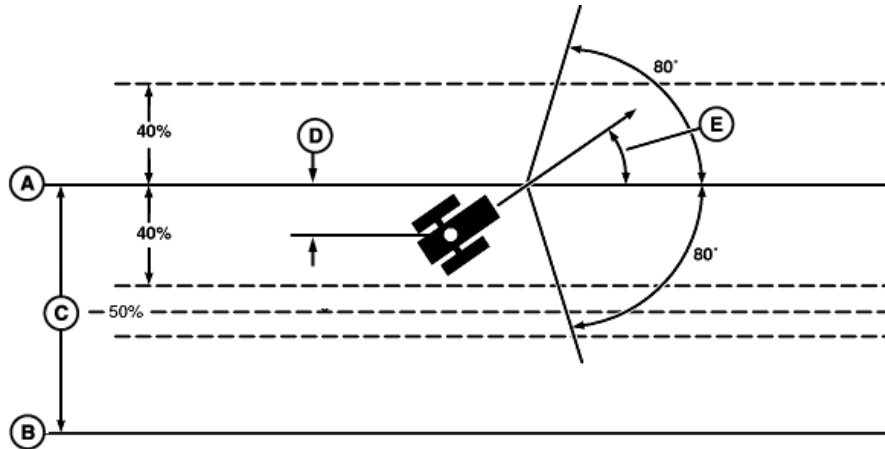

Tracking

A—Track 0  
B—Track 1 South

C—Track Spacing  
D—Off-Track Lateral Error

E—Track Heading Error

Once the end of the row is reached, the operator must turn system to next pass. By turning steering wheel, AutoTrac is deactivated.

AutoTrac can be activated again by pressing Resume Switch only after following conditions are met:

- Forward vehicle speed is less than 30 km/h (18.6 mph)
- Reverse speed is less than 10 km/h (6 mph).
- In reverse AutoTrac will remain activated for 45 seconds. After 45 seconds the machine must be put in a forward gear before reverse will activate again.

- Vehicle heading is within 80° of desired track.
- The machine is within 40% of track spacing
- Operator is seated.
- TCM is on.

*NOTE: The Track Number that is displayed at the top of the RUN PAGE changes at half the distance between two guidance tracks.*

CF86321,0000393 -19-01JUN11-1/1

PC8866—UN—02NOV05

## Deactivating AutoTrac

PC10857LA —UN—14APR09

**CAUTION:** Always turn off (Deactivate and Disable) AutoTrac system before entering a roadway.

To turn off AutoTrac, turn the Master Switch to the OFF position.

AutoTrac system can be made DEACTIVE by the following methods:

- Turning Master Switch to the OFF position.
- Turning steering wheel.
- Exceeding speed of 30 km/h (18.6 mph).
- Degradation of differential correction signal from SF2 or RTK to WAAS/ EGNOS for longer than 3 minutes.
- Selecting the STEER ON/OFF button.



Steer On/Off Softkey

- Operator out of seat for more than 7 seconds.
- Machine traveling less than 0.5 kph (0.3 mph) for 30 seconds.
- In reverse for longer than 45 seconds.
- Reverse speed exceeds 9.6 km/h (6 mph).

The master switch removes power from the EH Valve to prevent AutoTrac from being unintentionally activated. The master switch is intended for use on roadways or when the operator does not want AutoTrac able to be activated.

BA31779,0000240 -19-26JUL11-1/1

## Guidance Settings

Optimal performance of the GreenStar system usually requires adjustment of settings. Access Guidance settings to customize your user experience and optimize the system performance.

General Settings

**Turning View** - assists the operator view the next track when turning around. To turn ON/OFF, select / unselect check box.

**Turn Predictor** - alerts operator by predicting the end of pass. To turn ON/ OFF, select / unselect check box.

**Tracking Tones** – provide an audible indication off-track error. To turn ON/ OFF, select / unselect check box. To change distance at which tracking tones make a sound, select input field, scroll the thumb wheel to the desired value, and press Enter. Values between 10—60 cm (4—24 in.) may be entered.

**Lead Compensation** – shows how far down current track guidance looks to for such things as turns. It is used with

PC10857JN —UN—13APR09



GreenStar Main Page

PC10857JF —UN—13APR09



Settings

PC10857NG —UN—27APR09



Guidance Settings

Parallel Tracking only. To turn ON/OFF, select / unselect check box.

CF86321.0000395 -19-01JUN11-1/2

**Shift Track** – is used to adjust the position of guidance tracks left or right to compensate for GPS drift. This setting will turn shifts ON/OFF, select small shifts or large shifts, and change the distance of each shift.

**Shifts Off** – Check the box to turn shifts OFF.

**Small Shifts** – Select Small Shifts to use a Shift Size of 1—30 cm (0.4—12 in.).

**Large Shifts** – Select Large Shifts to use a Shift Size of 1— 410cm (12-161.5 in.). Large Shifts are disabled when AutoTrac is active or when operating in Adaptive Curve Track mode.

**Shift Size** – Distance that tracks shift when SHIFT LEFT or SHIFT RIGHT buttons are selected.

**ShiftTrack**

**Shifts Off**

**Small Shifts**

**Large Shifts**

Shift Size

1.0 (in)

A

F

PC10857NH —UN—27APR09

CF86321.0000395 -19-01JUN11-2/2

## AutoTrac Settings

PC10857LB —UN—14APR09

*NOTE: AutoTrac Settings only appear on the display in machines that are AutoTrac capable.*

**Steering Sensitivity**—Allows AutoTrac users to adjust the vehicle's steering sensitivity. To adjust steering sensitivity select the input box and enter the desired steering sensitivity value via numeric keypad and select the enter button. The sensitivity can also be adjusted up or down by selecting the Increase Steering Sensitivity and Decrease Steering Sensitivity softkeys on the Run Page.

*NOTE: Valid range for steer sensitivity is 50 - 200 with 200 being the most aggressive setting.*



Increase Steering Sensitivity

PC10857LC —UN—14APR09



Decrease Steering Sensitivity

BA31779,000024C -19-01AUG11-1/5

## Direction Toggle

PC13727 —UN—16MAY11

To be able to select the Direction Toggle Button the left region of the home page must be setup correctly. Setting up the left hand region will also allow the user to perform other operations.

1. Select the Layout Manager Button from the main menu



Layout Manager Button

Continued on next page

BA31779,000024C -19-01AUG11-2/5

- 2. In the layout manager home page select left region from the drop down menu (A).

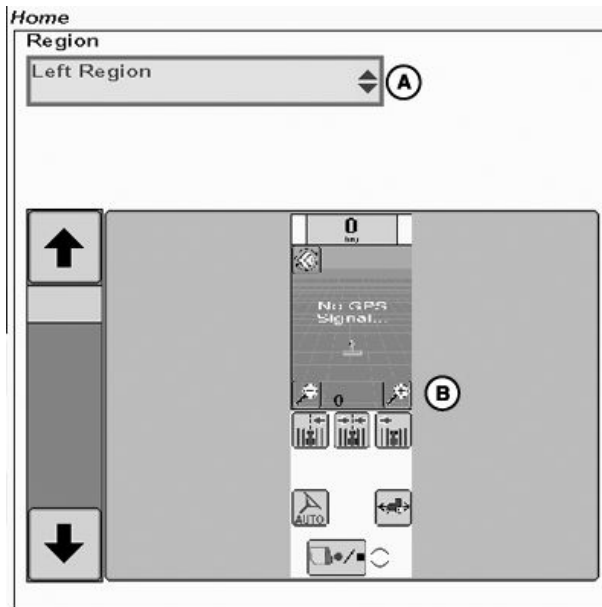

PC:13735 —UN—16MAY11

Layout Manager Home

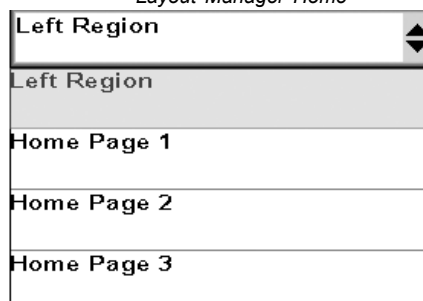

PC:13734 —UN—16MAY11

Region Select

3. In the setup selection (B) of the layout manager home screen select the left region that displays the Direction Toggle button (C).

- |                    |                       |
|--------------------|-----------------------|
| A—Drop Down Menu   | G—Center Track        |
| B—Setup Selection  | H—Shift Track Right   |
| C—Direction Toggle | I—Zoom Page Out       |
| D—AutoTrac On/Off  | J—Zoom Page IN        |
| E—Recording        | K—Toggle Mapping Mode |
| F—Shift Track Left |                       |



Left Region

PC13736 —UN—16MAY11

BA31779,000024C -19-01AUG11-4/5

The Direction toggle button can also be displayed on the right hand side of the Run Page by selecting the Settings Button on the run page.

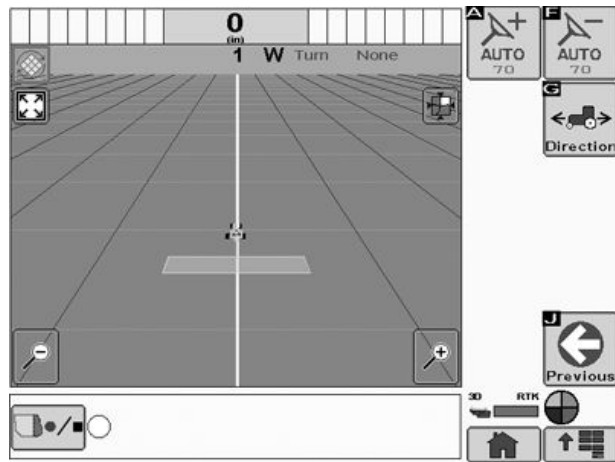

Run Page

PC13959 —UN—01AUG11



Settings

PC13963 —UN—01AUG11

BA31779,000024C -19-01AUG11-5/5

### Advanced AutoTrac Settings

To access the Advanced AutoTrac settings select the GreenStar button, select Settings Button, then select AutoTrac Settings from the Settings home page.

PC10857JN —UN—13APR09



GreenStar

PC10857JF —UN—13APR09



Settings

PC13713 —UN—16MAY11



AutoTrac Settings

Continued on next page

CF86321,0000397 -19-01JUN11-1/4

The AutoTrac Settings button will only be visible under Guidance Settings when an Steering Controller that supports advanced AutoTrac Integrated settings is detected.

The Accept button (K) saves and applies the current settings and returns the user to the previous page. The Restore Default Settings button (I) will set all settings to the factory default value. See each setting for its default value. Next page (J) will take the user to page 2 of the Advanced AutoTrac Settings. Selecting Previous page (L) will take the user to page 1 of the Advanced AutoTrac Settings The '?' button (A) will display a popup with help text for the specific setting.

- A—Help
- B—Steer Sensitivity
- C—Line Sensitivity Heading
- D—Line Sensitivity Tracking
- E—Heading Lead
- F—Steering Response Rate
- G—Curve Sensitivity
- H—Acquire Sensitivity
- I— Restore Default Settings
- J— Next Page
- K—Accept
- L—Previous Page

Advanced Settings

PC13714—UN—16MAY11

Advanced Settings

PC13715—UN—16MAY11

Continued on next page

CF86321,0000397 -19-01JUN11-2/4

Advanced Settings Help Information

### Line Sensitivity Heading

Determines how aggressively AutoTrac responds to heading error.

**Higher Settings:** Result in more aggressive response to vehicle heading error.

**Lower Settings:** Result in less aggressive response to vehicle heading error.



Line Sensitivity Heading



PC13716—UN—16MAY11

### Line Sensitivity Tracking

Determines how aggressively AutoTrac responds to off-track (lateral) error.

**Higher Settings:** Result in more aggressive response to vehicle off-track error.

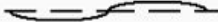
**Lower Settings:** Result in less aggressive response to vehicle off-track error.

Line Sensitivity  
Tracking Too Low

Line Sensitivity  
Tracking Too High



Line Sensitivity Tracking

PC13717—UN—16MAY11

### Heading Lead

Determines the impact of yaw rate (vehicle rate of turn) on tracking performance. Heading lead acts as a look-ahead parameter and can be used to minimize oversteering. Large adjustments may result in poor performance.

**Higher Settings:** Result in more aggressive response to yaw rate.

**Lower Settings:** Result in less aggressive response to yaw rate.



Heading Lead

PC13718—UN—16MAY11

### Steering Response Rate

Adjusts the rate of vehicle steering in order to maintain tracking performance. Increasing steering responsiveness generally results in better tracking performance.

**Higher Settings:** Result in better tracking performance but may also cause increased wheel motion or jittery behavior.

**Lower Settings:** Result in decreased wheel motion but may also result in worse tracking performance.

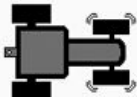



Steering Response Rate

PC13723—UN—16MAY11

Continued on next page

CF86321,0000397 -19-01JUN11-3/4

### Curve Sensitivity

Determines how aggressively AutoTrac responds to a curve in the track. This setting affects performance in curve track guidance only.

**Higher Settings:** Turn the vehicle in a smaller radius (tighter) around the curve.

**Lower Settings:** Turn the vehicle in a larger radius around the curve.

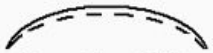

Curve Sensitivity  
Too Low

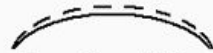

Curve Sensitivity  
Too High



Curve Sensitivity

PC13724 —UN—16MAY11

### Acquire Sensitivity

Determines how aggressively the vehicle acquires the track. This setting affects performance while acquiring the track only.

**Higher Settings:** Result in more aggressive line acquisitions.

**Lower Settings:** Result in smoother line acquisitions.

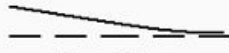

Acquisition  
Sensitivity Too Low



Acquisition  
Sensitivity Too High



Acquire Sensitivity

PC13725 —UN—16MAY11

CF86321,0000397 -19-01JUN11-4/4

## StarFire

AutoTrac controller takes its StarFire Height and Fore-Aft measurements from the StarFire setup. To change this information select the menu button then select the StarFire button. The StarFire main page will appear. Select the Setup tab (A) at the top of the screen.

PC8663 —UN—05AUG05



Menu Button

PC13738 —UN—17MAY11

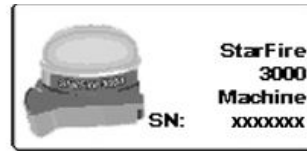

SF3000 Button

Continued on next page

BA31779,0000225 -19-08JUL11-1/2

**StarFire Height (in.)** Enter the height of the StarFire receiver into the Height box (C) of the StarFire Setup screen. Height is measured from the ground to the center (where the green and yellow meet) of the dome.

**StarFire Fore-Aft (in.)** Enter the Fore-Aft measurement into the Fore/Aft box (B) of the StarFire Setup screen. This is the distance from the fixed axle of the machine to the receiver. The fixed axle is the rear axle on a row crop tractor. The fixed axle is the front axle on an articulated tractor

*NOTE: For more information on StarFire setup see the StarFire operators manual that matches your equipment.*

StarFire 3000 - Main SN: xxxxx

Info	<b>A</b> Setup	Activations	Serial Port
------	----------------	-------------	-------------

StarFire

Correction Mode  
RTK

Default  Correction freq  
1545.5450

Mount Direction  
Forward

Fore/Aft (in)  
**B** 24

Height (in)  
**C** 130

Enable Optimize Shading

Hours On After Shutdown  
3

3D TCM  
On  Off

Last Calibration: Machine

StarFire Setup Screen

PC13726—UN—19MAY11

BA31779,0000225 -19-08JUL11-2/2

# Troubleshooting—GS2 Display 1800

## Trouble Codes

Select TROUBLE CODES button, a list of controllers will appear and controllers with diagnostic codes are indicated.

Individual controllers can be accessed by navigating with rotary thumb wheel and selected by pressing ENTER button, to view codes for that controller.

Codes can also be displayed for all controllers by selecting SHOW ALL button with rotary thumb wheel and pressing ENTER button. Codes can be relayed to a John Deere dealer to assist in diagnosing machine problems.

PC8663 —UN—05AUG05



MENU button

PC8655 —UN—05AUG05



MESSAGE CENTER button (With Info Icon)

PC8669 —UN—05AUG05



TROUBLE CODES softkey

CF86321,0000331 -19-23MAY11-1/1

## Diagnostic Addresses

MESSAGE CENTER button >> DIAGNOSTIC ADDRESSES softkey >> DEVICE drop down box >> "VT;.001 Implement"

PC8655 —UN—05AUG05



MESSAGE CENTER button

PC8668 —UN—05AUG05

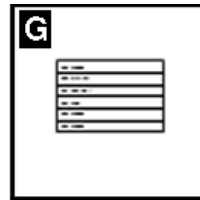

DIAGNOSTIC ADDRESSES softkey

Continued on next page

CF86321,0000332 -19-23MAY11-1/2

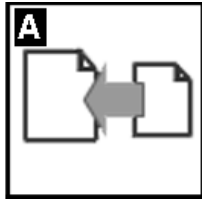

*COMPONENTS AND SOFTWARE VERSIONS softkey*

PC8666 —UN—05AUG05

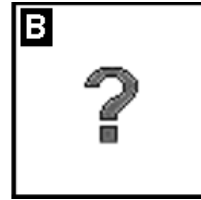

*SOFTWARE INFORMATION softkey*

PC8666 —UN—05AUG05

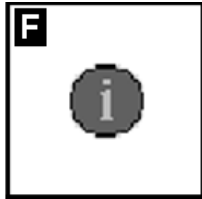

*MESSAGES softkey*

PC8667 —UN—05AUG05



*DIAGNOSTIC ADDRESSES softkey*

PC8668 —UN—05AUG05



*TROUBLE CODES softkey*

PC8669 —UN—05AUG05

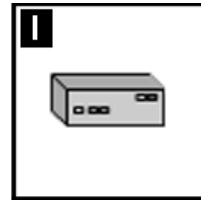

*Electronic CONTROL UNIT INFORMATION softkey*

PC8670 —UN—05AUG05

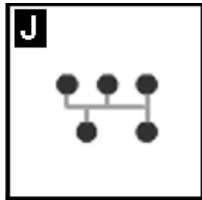

*BUS INFORMATION softkey*

PC8671 —UN—05AUG05

Message center will display all active alarm messages.

CF86321.0000332 -19-23MAY11-2/2

## Guidance Alarms

ACI Communication Error	No communication with vehicle steering controller (Steering Controller). Check vehicle for diagnostic codes and contact your John Deere Dealer.
Turn Predictor Turned On	Turn predictor is turned ON. Use the check box to turn it OFF
AutoTrac Deactivated	AutoTrac system deactivates when operator is out of seat for more than 5 seconds
AutoTrac	The operator is responsible for collision avoidance. Turn AutoTrac OFF before entering roadways.
Data Card Problem!	A data card must be inserted in the compact flash drive with the door closed to use the GreenStar2 Pro application.
No Setup Data!	Setup data for the GreenStar2 Pro application could not be found on the data card. The GreenStar2 Pro application will not be available until a data card with setup data is inserted
AutoTrac Steering Controller Software Incompatible	See your John Deere Dealer for Steering Controller update.
Communication Error	Communication problem with controller. Check connections to controller.
Mobile Processor Detected	Mobile Processor Detected on CAN Bus. GreenStar Application is disabled. Remove mobile processor and cycle power to enable GreenStar application.
GPS Communication Problem	No communication with GPS receiver. Check connections at GPS receiver.
Tracking Inaccurate	The GPS receiver must be set to report at the 5Hz message output rate. Confirm settings on GPS receiver and change output to 5Hz,
Invalid Boundary	An invalid boundary has been recorded. You may continue recording or clear the current boundary and start recording again.
Activation Error	Invalid activation code. Please reenter activation code.
Invalid Filter	All the fields that are required to be filled out based on the Totals Type Selected have not been filled out.
Flags of Same Selection	Selected the Flags of same name and mode.
Name Already Exists	The name you have entered already exists in this list. Please enter a new name.

### Alarms

GPS Communication Problem	No communication with GPS receiver. Check connection at GPS receiver and perform operation again.
Curve Track Memory Full	Internal memory available for Curve Track is full. Data must be cleared to continue Curve Track Operation. Clear curved track data from system
AutoTrac Disabled	AutoTrac SF1 license cannot operate with current StarFire software. Update StarFire software to operate AutoTrac.
AutoTrac Disabled	AutoTrac SF1 license cannot operate while SF2 corrections are turned on. Turn SF2 corrections off to operate AutoTrac.
License Problem	No license available for the selected tracking mode. Previous tracking mode will be selected.
Duplicate Name	Name already exists. Select another name.
Curve Track Recording	Curve Track recording in progress. Cannot perform operation until recording is turned off.
Circle Definition Problem	There was an internal error during Circle definition. Redefine the circle.
Circle Definition Problem	Communication with GPS receiver was lost during circle definition. Redefine the circle once communication has been re-established.
Circle Definition Problem	Center point is too far. Select another center point.
A-B Line Definition Problem	There was an internal error during A-B line definition. Redefine the A-B line.
A-B Line Definition Problem	A timeout occurred during A-B line definition. Redefine the A-B line.
A-B Line Definition Problem	A and B points of the A-B line are too close. Perform operation again.
Loss of GPS While Recording Boundary	GPS has been lost while recording the boundary. Point logging will resume when the GPS signal returns. This may result in an inaccurate boundary.
Data Card Full	Unload and cleanup data card or insert new data card.
Data Card 90% Full	Unload and cleanup data card or insert new data card.
No Memory	No Memory available for Curve Track. Unload and cleanup data card or insert new data card.
Low Memory	Low Memory available for Curve Track. Unload and cleanup data card or insert new data card.
No Memory	No Memory available for Straight Track. Unload and cleanup data card or insert new data card.
No Memory	No Memory available for Circle Track. Unload and cleanup data card or insert new data card.
Circle Definition Problem	The distance from the vehicle to the center point is greater than 1 mile. Select another center point or drive another circle.
Zero All Totals	You have decided to zero all totals for the selected filter.
Incorrect RS232 Controller Model Selected	The RS232 controller model selected is incorrect. Please verify and reenter manufacturer and model number.
Prescription Error	Controller is not setup to accept prescriptions.

Continued on next page

CF86321,0000333 -19-23MAY11-1/2

Prescription Error	Controller is setup to accept prescriptions. No controller prescription has been selected.
Prescription Error	Prescription rate is out of controller range.
Controller Unit of Measure Error	Controller will only operate when using metric units.
Controller Unit of Measure Error	Controller will only operate when using English (US) units.
Controller Unit of Measure Error	Controller will only operate when using metric or English (US) units.
Controller Operation Error	Invalid operation selected for controller.
Prescription Warning	Out of field prescription rate is now being applied.
Prescription Warning	Loss of GPS signal has occurred. Loss of GPS prescription rate is now being applied.
Prescription Warning	Controller does not support selected prescription.

INFO

CF86321,0000333 -19-23MAY11-2/2

## AutoTrac Deactivation Message

**AutoTrac deactivation message**—Each time AutoTrac is deactivated text is displayed indicating the reason

why AutoTrac deactivated. Messages are also displayed as to why AutoTrac did not activate. The deactivation messages display for 3 seconds and then disappear.

AutoTrac Deactivation Message	
Deactivation Message	Description
Steering wheel moved	Operator turned steering wheel
Speed too slow	Vehicle speed is below minimum required speed
Speed too fast	Vehicle speed is above maximum allowed speed
Invalid gear	Vehicle operating in an invalid gear
Track number changed	Track number changed
Invalid GPS signal	SF1, SF2, or RTK signal was lost
Steering Controller fault	See John Deere dealer
Invalid display messages	Check display settings
Invalid display settings	Check guidance settings and Track 0 setup
No AutoTrac Activation	No AutoTrac Activation on GS2
Heading error too large	Vehicle is at an angle greater than 45 degrees from track
Offtrack error too large	Vehicle not within 40% of track spacing
Out of seat	Out of seat too long
Oil temp too cold	Hydraulic oil not above minimum required temperature
No TCM corrections	Make sure TCM is turned on
Invalid Steering Controller activation	Need Steering Controller activation code. See John Deere dealer.
FICA in diagnostic mode	Fuse is in diagnostic slot in vehicle fuse box. remove fuse.
Header off	Header was turned off
Road mode	In transport gear
Invalid Steering Controller voltage	See John Deere dealer
Reverse timeout	In reverse gear for more than 45 seconds
Vehicle too slow	AutoTrac below minimum speed
Curve too sharp	Maximum curvature has been exceeded
Vehicle not moving in a forward direction	Vehicle must be in forward gear to activate
Vehicle shutting down	Vehicle is shutting down
Gear data error	See John Deere dealer
Resume switch error	See John Deere dealer
Keyswitch error	See John Deere dealer
SPFH AutoTrac switch is not on	Make sure SPFH AutoTrac switch is turned on
SPFH Quick Stop switch is on	Make sure SPFH Quick Stop switch is turned off

CF86321,0000334 -19-23MAY11-1/1

## Diagnostic Addresses

### Diagnostic Addresses

*NOTE: Diagnostic addresses are available to access specific diagnostic information. This information can assist the John Deere Dealer in diagnosing problems. Different device controllers can be selected from drop-down box, as shown.*

Select DIAGNOSTIC ADDRESSES button. The number of devices available will depend upon machine configuration. The list of addresses can be scrolled up or down with rotary thumb wheel. Selecting an address will show data for that address.

PC8663 —UN—05AUG05



MENU button

PC8655 —UN—05AUG05



MESSAGE CENTER button (With Info Icon)

PC8668 —UN—05AUG05

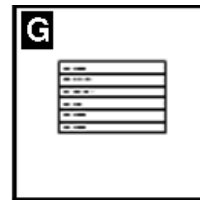

DIAGNOSTIC ADDRESSES softkey

Address Number	Address Name
008	Unswitched Power Supply Voltage
009	Switched Power Supply Voltage
010	Unit Internal Temperature
011	Vehicle CAN - Bus Status
012	Vehicle CAN - CAN HIGH Voltage
013	Vehicle CAN - CAN LOW Voltage
015	Implement CAN - Bus Status
016	Implement CAN - CAN HIGH Voltage
017	Implement CAN - CAN LOW Voltage
018	Flash Wear Count
019	Hours of Operation
020	1.5 v Regulated Power Supply Voltage
021	3.3 v Regulated Power Supply Voltage
022	5.0 v Regulated Power Supply Voltage
023	Radar Input Status
024	Implement Switch Status
025	External Analog Input Voltage
026	Compact Flash Drive Status
028	CCD Bus - Bus Status
029	CCD Bus - Positive Voltage
030	CCD Bus - Negative Voltage
031	Bezel Key Status
032	Real Time Clock (RTC)
033	Maximum Sleep Time
038	Synchronize Brightness
039	Daytime Luminance
040	Daytime Luminance Balance Ratio
041	Nighttime Luminance
042	Nighttime Luminance Balance Ratio

Continued on next page

CF86321,0000335 -19-23MAY11-1/2

Address Number	Address Name
043	Internal Speaker Volume
044	Display ISO Function Instance
045	Settings - Country Code
046	Settings - Language Code
047	Settings - Numeric Format
048	Settings - Date Format
049	Settings - Time Format
050	Settings - Units of Distance
051	Settings - Units of Area
052	Settings - Units of Volume
053	Settings - Units of Mass
054	Settings - Units of Temperature
055	Settings - Units of Pressure
056	Settings - Units of Force
057	Settings - GPS Time Sync
058	Settings - Current Date
059	Settings - Current Time
060	Radar Calibration Constant
227	Boot Block Program Part Number (Software)
228	Boot Block Program Version Number (Software)
231	Board Service Package Part Number (Software)
232	Board Service Package Version Number (Software)
233	Virtual Terminal Part Number (Software)
234	Virtual Terminal Version Number (Software)
235	Device Part Number (Hardware)
236	Device Serial Number (Hardware)
247	Current Vehicle Model Number
248	Current Vehicle Serial Number
249	Original Vehicle Model Number
250	Original Vehicle Serial Number

CF86321,0000335 -19-23MAY11-2/2

# GS3 2630 Display

## Automatic Guidance System Detected

Each time a machine equipped with AutoTrac is started, this screen will appear as a reminder of operator responsibilities when using AutoTrac steering system.

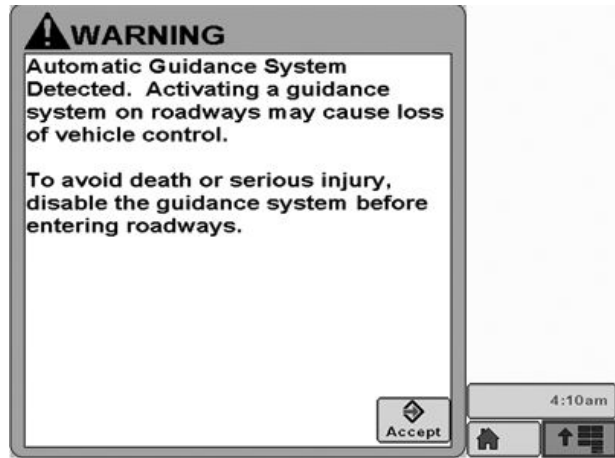

Automatic Guidance

CF86321,0000399 -19-01JUN11-1/1

PC13157 —19—17FEB11

## Enabling System

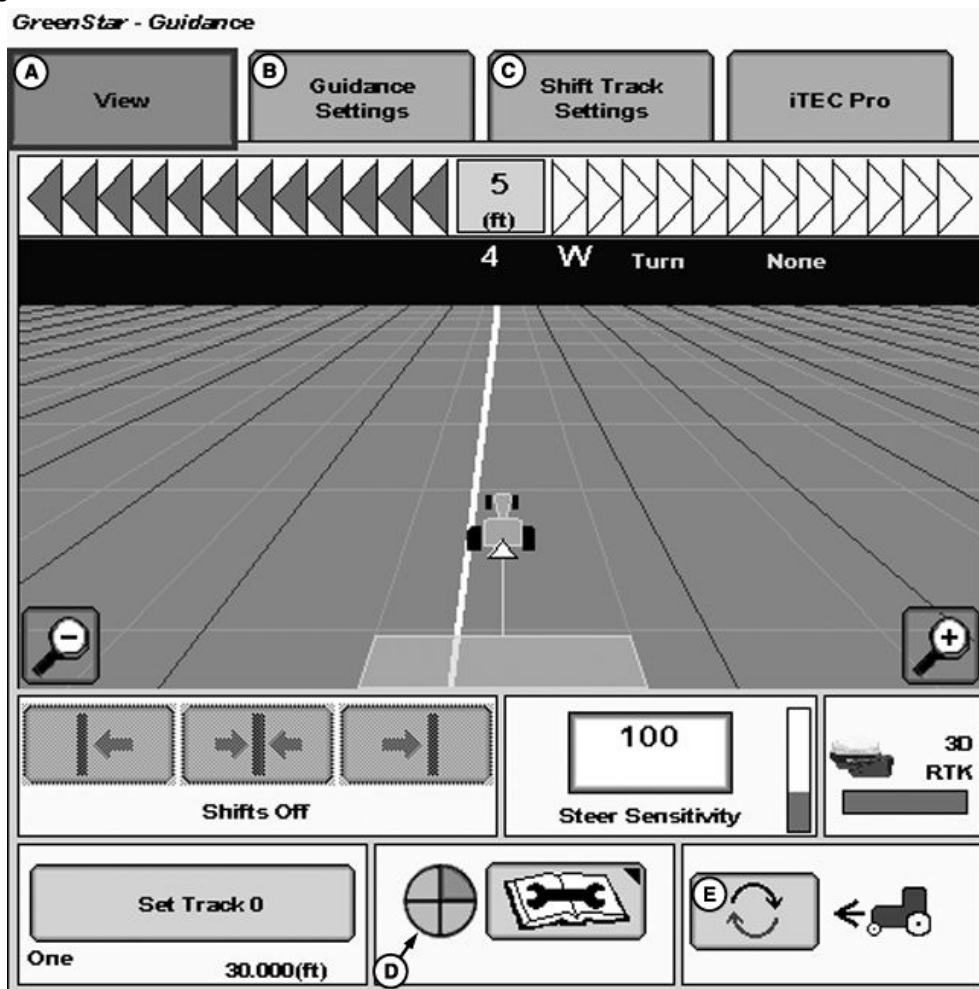

GreenStar Pro

A—View Tab  
B—Guidance Settings Tab

C—ShiftTrac Settings  
D—AutoTrac Status Pie

E—Change Direction Toggle Button

Press STEER ON/OFF button to toggle between enable/disable AutoTrac.

To enable system, all of the following criteria must be met:

- AutoTrac activation is detected.

- Track 0 has been setup.
- Tracking mode selected.
- Proper operator presence mode selected.
- TCM must be installed and turned on.
- AutoTrac Controller Steering Kit is plugged in.

CF86321.000039A -19-28JUN11-1/1

PC13825 —UN—28JUN11

## Activating System

**⚠ CAUTION: While AutoTrac is activated, operator is responsible for steering at end of path and collision avoidance.**

**Do not attempt to turn on (Activate) AutoTrac system while transporting on a roadway.**

After system has been ENABLED, operator must manually change system to ACTIVATED status when steering assistance is desired.

**Press resume switch.** This will initiate assisted steering.

In order to activate system following criteria must be met:

- Vehicle speed is greater than 0.5 km/h (0.3 mph).
- Forward vehicle speed is less than 30 km/h (18.6 mph)
- Reverse vehicle speed is less than 10 km/h (6.0 mph).
- Vehicle within 45 degrees of desired track.
- Operator is seated.
- TCM is on.
- In reverse AutoTrac will remain activated for 45 seconds. After 45 seconds the machine must be put in a forward gear before reverse will activate again.

CF86321,000039B -19-01JUN11-1/1

## Deactivating System

**⚠ CAUTION: Always turn off (Deactivate and Disable) AutoTrac system before entering a roadway.**

**To turn off AutoTrac, turn the Master Switch to the OFF position.**

AutoTrac system can be made DEACTIVE by following methods:

- Turning Master Switch to the OFF position.
- Turning steering wheel.
- Slowing to speeds less than 0.5 km/h (0.3 mph).

- Exceeding forward speed of 30 km/h (18.6 mph)
- Exceeding reverse speed of 10 km/h (6.0 mph).
- Toggle STEER ON/OFF button until STEER OFF is displayed in GUIDANCE VIEW tab.
- Operator out of seat for more than 5 seconds if using seat switch or no activity detected by operator presence monitor for 7 minutes.

The master switch removes power from the EH Valve to prevent AutoTrac from being unintentionally activated. The master switch is intended for use on roadways or when the operator does not want AutoTrac able to be activated.

BA31779,0000241 -19-26JUL11-1/1

## Setup

### Advanced AutoTrac Settings

The accept button (K) shall save and apply the current settings and return the user to the previous page. The Restore Default Settings button (K) will set all settings to the factory default value. See each setting for its default value. The '?' button (H) will display a pop-up with help information. Refer to **Advanced settings — Optimizing AutoTrac Controller Performance** section of this operator manual for more information.

*NOTE: When using the number pad, increase, and decrease buttons, the change occurs immediately without pressing the enter button.*

*When no seat switch is present, the AutoTrac Controller will look for operator activity every seven minutes. Operator will get a time out alarm 15 seconds before AutoTrac will deactivate. Pressing resume will reset activity monitor timer*

**IMPORTANT: Use AutoTrac Controller only on Approved Vehicles – see [www.StellarSupport.com](http://www.StellarSupport.com) for list of approved vehicles**

**It is important that the operator stay seated while vehicle is moving.**

- |                             |                        |
|-----------------------------|------------------------|
| A—Line Sensitivity-Tracking | I— Page Back Button    |
| B—Line Sensitivity-Heading  | J— Page Forward Button |
| C—Heading Lead              | K—Accept Button        |
| D—Steering Response Rate    | L—Aquire Sensitivity   |
| E—Decrease Button           | M—Curve Sensitivity    |
| F—Value                     | N—Restore Defaults     |
| G—Increase Button           | O—Monitor Performance  |
| H—Help Button               |                        |

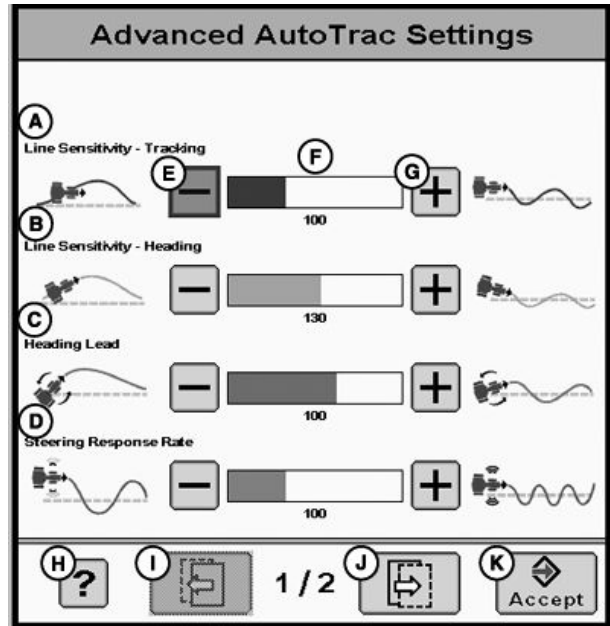

Advanced Settings Page 1

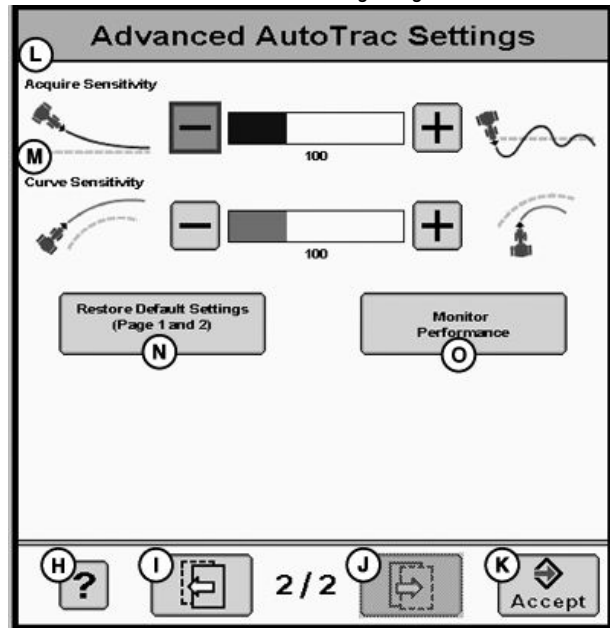

Advanced Settings Page 2

CF86321,000039D -19-01JUN11-1/1

PC13568 —UN—04MAY11

PC13569 —UN—04MAY11

**StarFire**

AutoTrac controller takes its StarFire Height and Fore-Aft measurements from the StarFire setup. To change this information select the menu button then select the StarFire button. The StarFire main page will appear. Select the Setup tab (A) at the top of the screen.

PC8663 —UN—05AUG05



Menu Button

PC13738 —UN—17MAY11



SF3000 Button

BA31779,0000226 -19-08JUL11-1/2

**StarFire Height (in.)** Enter the height of the StarFire receiver into the Height box (C) of the StarFire Setup screen. Height is measured from the ground to the center (where the green and yellow meet) of the dome.

**StarFire Fore-Aft (in.)** Enter the Fore-Aft measurement into the Fore/Aft box (B) of the StarFire Setup screen. This is the distance from the fixed axle of the machine to the receiver. The fixed axle is the rear axle on a row crop tractor. The fixed axle is the front axle on an articulated tractor

*NOTE: For more information on StarFire setup see the StarFire operators manual that matches your equipment.*

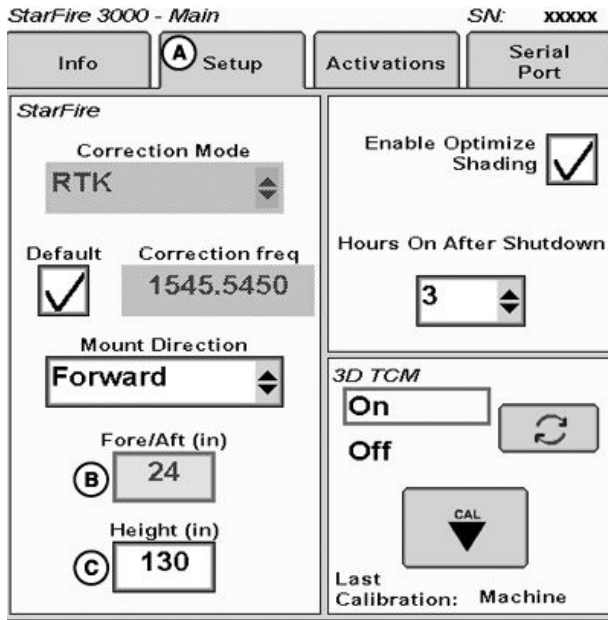

StarFire Setup Screen

PC13726 —UN—19MAY11

BA31779,0000226 -19-08JUL11-2/2

# GS3 2630 Advanced Settings

## Tuning Recommendations

*NOTE: AutoTrac Controller has been tuned to perform very well in most field conditions using the variety of implements encountered by AutoTrac. However, for those conditions outside of normal, we have provided Advanced Settings to allow the operator fine tune their systems for specific field conditions and implements.*

### Problem or Situation:

AutoTrac performance during line acquisitions, Curve Trac or in-row S-ing that can't be tuned out using the Steering Sensitivity adjustment.

Difficult ground conditions (extremely soft or extremely rough) require additional tuning beyond the capabilities of the standard Steering Sensitivity value.

**Read this information in it's entirety BEFORE tuning AutoTrac Advanced Settings.**

This software version includes 6 different tunable sensitivities that allow finer adjustment of the AutoTrac system. The following are details for tuning this software:

1. **Check & fix other problems before you tune**—Perform necessary mechanical checks and calibrations through associated tractor. It is important to do this step first otherwise you run the risk of masking actual machine faults and wasting your time tuning a system that cannot be tuned.
  2. **Characterize the current AutoTrac problem**—There are various types of issues this software may be able to resolve. First, the specific type of problem needs to be identified from the possible items below:
    - a. **Excessive Wheel Motion**—Overall AutoTrac performance is acceptable, but the operator is concerned about how quickly the wheels are twitching back and forth.
    - b. **Aggressive S-ing Motion**—Continual back and forth motion as observed by the operator looking out over the front nose of the tractor. Although a lot of motion is observed, the off-track error shown on the display (distance away from AB line) is often relatively small.
    - c. **Lazy S-ing Motion**—Performance of AutoTrac seems very sluggish when trying to stay on the line and slowly wanders from side to side.
    - d. **Lazy Line Acquisition**—AutoTrac appears sluggish during line acquisition and the tractor remains off to one side of the line for a long time before getting lined up.
    - e. **Aggressive Line Acquisition**—AutoTrac overshoots the line, and continues to overcompensate during acquisition. Results in high frequency, tight S-ing pattern during acquisitions.
    - f. **Lazy Curve Track Performance**—AutoTrac is sluggish in Curve Track mode resulting in slow, wandering S-ing about the desired line and often tracks to the outside of the desired path.
    - g. **Aggressive Curve Track Performance**—AutoTrac exhibits rapid and high frequency corrections in Curve Track mode, resulting in a tight S-ing pattern or tracking to the inside of the desired path.
3. **Access the Advanced Settings page on GS2.**
  4. **ATI Advanced Settings Parameters.**
    - a. **Line Sensitivity Heading:** Determines how aggressively AutoTrac responds to heading error. Higher Settings: Result in more aggressive response to vehicle heading error. Lower settings: Result in less aggressive response to vehicle heading error. Range: 50 to 200.
    - b. **Line Sensitivity Tracking (Lateral Gain):** Determines how aggressively AutoTrac responds to off-track (lateral) error. Higher settings: Result in more aggressive response to vehicle off-track error. Lower settings: Result in less aggressive response to vehicle off-track error. Range: 50 to 200.
    - c. **Heading Lead:** Determines the impact of yaw rate (vehicle rate of turn) on tracking performance. Heading lead acts as a look-ahead parameter and can be used to minimize over steering. Large adjustments may result in poor performance. Higher settings: Result in more aggressive response to yaw rate. Lower settings: Result in less aggressive response to yaw rate. Range: 50 to 130.
    - d. **Steering Response Rate:** Adjusts the rate of vehicle steering in order to maintain tracking performance. Increasing steering responsiveness generally results in better tracking performance. Higher settings: Result in better tracking performance but may also cause increased wheel motion or jittery behavior. Lower settings: Results in decreased wheel motion but may also result in worse tracking performance. Range: 50 to 200.
    - e. **Curve Sensitivity:** Determines how aggressively AutoTrac responds to a curve in the track. This setting affects performance in curve track guidance only.

Continued on next page

CF86321.000027B -19-16MAY11-1/2

Higher settings: Turn the vehicle in a smaller radius (tighter) around the curve.  
 Lower settings: Turn the vehicle in a larger radius around the curve.  
 Range: 50 to 200.

- f. **Acquire Sensitivity:** Determines how aggressively the vehicle acquires the track. This setting affects performance while acquiring the track only.  
 High settings: Result in more aggressive line acquisitions.  
 Lower settings: Result in smoother line acquisitions.  
 Range: 50 to 200.

5. **Follow Tuning Instructions**—First try to adjust the settings based on how it was characterized in Step 2. If familiar with how the settings affect performance, proceed to the general tuning instructions if desired. Although the customer’s comfort needs to be taken into account, try to tune the tractor based on lateral error on the GS2 and the tracks that tractor leaves behind. After finding a reasonable set of parameters, try running the tractor at different speeds to ensure the settings are still acceptable. Sometimes the settings that maximize AutoTrac performance are very close to making the operator feel uncomfortable.

**General Tuning Instructions**

Adjustment Recommendations:

- **Steering Sensitivity**—Set at 100 before making other adjustments – after that make adjustments in increments of 10.
- **Line Sensitivity Tracking**—Adjust in increments of 20.
- **Line Sensitivity Heading**—Adjust in increments of 10.
- **Heading Lead**—Adjust in increments of 10.
- **Steering Response Rate**—Adjust in increments of 10.

- **Acquire Sensitivity**—Adjust in increments of 20.

- **Curve Sensitivity**—Adjust in increments of 20.

**One Value at a Time**—Attempt to adjust the settings in the problem field conditions while AutoTrac is active.

1. **Start with the factory default settings.** The Steering Sensitivity value will correlate to the value on the Guidance View Tap. Attempt to use a value for this setting that is similar to the conditions in which you are running (70 for concrete, 100 most conditions, 120 for soft ground). This number may still need to be modified beyond the suggested settings.
2. While AutoTrac is active in the problem conditions (speeds, ground, tire setup, etc), increase/reduce the **Line Sensitivity Heading** by a factor of 10.
3. If the change in Line Sensitivity Heading is ineffective at addressing the issue, reset the Line Sensitivity Heading parameter and increase/reduce the **Heading Lead** in the same manner as the previous step.
4. If none of the previous steps were effective reset the Heading Lead and increase/reduce the **Steering Response Rate** in a similar fashion to the previous steps.

**Combining Settings**—If the above procedure does not give satisfactory performance and once you have become more comfortable with how the parameters change AutoTrac performance (as detailed in the previous step), try different combinations of parameters while AutoTrac is active. The following chart should be used as a reference and contains suggested values based on various types of conditions, please note that values may need to be adjusted beyond these recommendations to achieve satisfactory performance.

To return all settings to their default values, use the “Return To Defaults” button provided at the bottom of the Advanced Settings screen.

CF86321,000027B -19-16MAY11-2/2

### Recommended Tuning Settings

Settings	Factory Defaults	Min Value	Max Value	Excessive Wheel Motion	Aggressive S-ing Motion	Lazy S-ing Motion
Overall Steering Sensitivity	70	50	200	100	100	100
Line Sensitivity Heading	100	50	200	100-Decrease as necessary	80-Decrease as necessary ( <b>start here</b> )	100-Increase as necessary ( <b>start here</b> )
Line Sensitivity Tracking	100	50	200	100	100	100-Increase as necessary
Heading Lead	100	50	130	90	90-Decrease as necessary	90
Steering Response Rate	100	50	200	80-Decrease as necessary ( <b>start here</b> )	100	100-Increase as necessary
Curve Sensitivity	70	50	200	100	100	100
Acquire Sensitivity	100	50	200	100	100	100

Settings	Wandering S-ing Motion	Lazy Line Acquisitions	Aggressive Line Acquisitions	Lazy Curve Track Performance	Aggressive Curve Track Performance
Overall Steering Sensitivity	100	100	100	100	100
Line Sensitivity Heading	100-Decrease as necessary	100	100-Decrease as necessary	100-Increase as necessary	100-Decrease as necessary
Line Sensitivity Tracking	100-Increase as necessary	150-Increase as necessary	100-Decrease as necessary	100	100
Heading Lead	100-Increase as necessary ( <b>start here</b> )	90	90	90-Increase as necessary	90
Steering Response Rate	100-Increase as necessary	100	100	100-Increase as necessary	100
Curve Sensitivity	70	100	100	110-Increase as necessary ( <b>start here</b> )	90-Decrease as necessary ( <b>start here</b> )
Acquire Sensitivity	100	120-Increase as necessary ( <b>start here</b> )	80-Decrease as necessary ( <b>start here</b> )	100	100

#### Most Common Conditions

- Excessive Wheel Motion**—Adjust Steering Response Rate first before making any other adjustments. Turn down this parameter until an acceptable amount of wheel motion exists. Although it may be possible for this parameter to be changed independently, you may need to increase Line Sensitivity Heading and/or Line Sensitivity Tracking (lateral) gains to compensate for the wheel motion decrease. Keep in mind that forcing this value too low may compromise AutoTrac accuracy because this responsiveness determines how quickly the system can compensate for off-track error. The recommended Steering Wheel Speed setting should be adjusted until there is slightly less wheel motion than what is considered excessive by the operator.
- Aggressive S-ing Motion**—The two main adjustments to address aggressive s-ing motion are Line Sensitivity Heading and Heading Lead. Start by increasing Heading Lead to enable the system to

look further ahead when making corrections. If this is unsuccessful, the likely cause is overaggressive Line Sensitivity Heading and this gain should then be reduced. Forcing this gain low may require an increase in the Line Sensitivity Tracking (Lateral) gain to maintain the overall system performance at an acceptable level.

- Lazy S-ing Motion**—This may be the most difficult situation to address because the sluggish behavior can be caused by field conditions or machine setup. In some cases, tuning the gains may not achieve the performance desired. Start by increasing Line Sensitivity Tracking and check performance. If the system remains sluggish, increase Line Sensitivity Heading until the system begins to respond more aggressively. If fine tuning is needed, the Steering Response Rate can be adjusted accordingly, increasing this value will make the system more aggressive.

CF86321,000027C -19-16MAY11-1/1

## Optimizing AutoTrac Controller Performance

When operating in curves, start with the curve sensitivity equal to the optimized acquire sensitivity.

These default settings are a good starting point for most conditions. Each setting can be adjusted to try and optimize performance. Operator may need to readjust line sensitivity - heading and line sensitivity - tracking for best results. Increase or decrease settings to change aggressiveness as desired. If system is not responsive enough, increase sensitivity settings. If desired performance is not achieved, see TROUBLESHOOTING section for more detail.

### Line Sensitivity Tracking

Determines how aggressively AutoTrac responds to off-track (lateral) error.

Higher settings: Results in more aggressive response to vehicle off-track error.

Lower Settings: Results in less aggressive response to vehicle off-track error.

A—Heading Error

B—Tracking Error

### Advanced AutoTrac Settings

**Line Sensitivity Tracking**

Determines how aggressively AutoTrac responds to off-track (lateral) error.

**Higher Settings:** Result in more aggressive response to vehicle off-track error.

**Lower Settings:** Result in less aggressive response to vehicle off-track error.



Line Sensitivity Tracking Too Low



Line Sensitivity Tracking Too High

1 / 6

Line Sensitivity Tracking

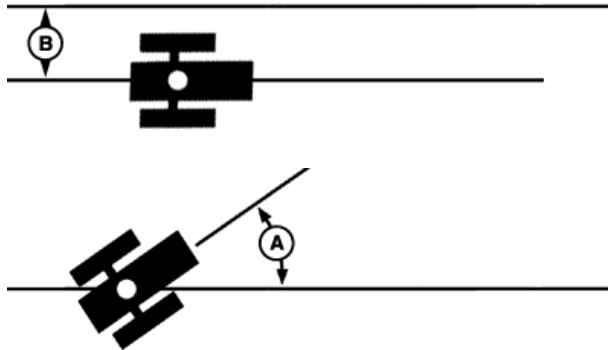

Continued on next page

CF86321,000027D -19-16MAY11-1/9

PC13570—UN—04MAY11

PC8993—UN—09MAR06

PC8994—UN—07MAR06

**Line Sensitivity Heading**

Determines how aggressively AutoTrac responds to heading errors.

Higher settings: Result in more aggressive response to vehicle heading error.

Lower settings: Result in less aggressive response to vehicle heading error.

**Advanced AutoTrac Settings**

**Line Sensitivity heading**

Determines how aggressively AutoTrac responds to heading error.

**Higher Settings:** Result in more aggressive response to vehicle heading error.

**Lower Settings:** Result in less aggressive response to vehicle heading error.



Line Sensitivity Heading Too Low



Line Sensitivity Heading Too High



2 / 6





Line Sensitivity Heading

CF86321,000027D -19-16MAY11-2/9

PC13571—UN—04MAY11

**Heading Lead**

Determines the impact of yaw rate (vehicle rate of turn) on tracking performance. This can be thought of as a look-ahead parameter. Large adjustments may result in poor performance.

Higher settings: Results in more aggressive response to vehicle twist.

Lower Settings: Results in less aggressive response to vehicle twist.

**Advanced AutoTrac Settings**

**Heading Lead**

Determines the impact of yaw rate (vehicle rate of turn) on tracking performance. Heading lead acts as a look-ahead parameter and can be used to minimize oversteering. Large adjustments may result in poor performance.

**Higher Settings:** Result in more aggressive response to yaw rate.

**Lower Settings:** Result in less aggressive response to yaw rate.



Heading Lead Too Low



Heading Lead Too High



3 / 6





Heading Lead

Continued on next page

CF86321,000027D -19-16MAY11-3/9

PC13573—UN—04MAY11

**Steering response Rate**

Adjusts the rate of vehicle steering in order to maintain tracking performance. Increasing steering responsiveness generally results in better tracking performance.

Higher settings: Results in better tracking performance but may also cause increased wheel motion or jittery behavior.

Lower Settings: Results in decreased wheel motion but may also result in worse tracking performance.

**Advanced AutoTrac Settings**

**Steering Response Rate**

Adjusts the rate of vehicle steering in order to maintain tracking performance. Increasing steering responsiveness generally results in better tracking performance.

**Higher Settings:** Result in better tracking performance but may also cause increased wheel motion or jittery behavior.

**Lower Settings:** Result in decreased wheel motion but may also result in worse tracking performance.

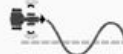

Steering Response Rate Too Low



Steering Response Rate Too High



4 / 6





Steering Response Rate

CF86321,000027D -19-16MAY11-4/9

PCI3572 — JUN — 04MAY11

**Acquire Sensitivity**

Determines how aggressively the vehicle acquires the track. This setting affects performance while acquiring the track only.

High settings: Results in a more aggressive track line acquisition.

Lower settings: Results will give smoother entry into the next track.

**Step 1: Optimize Steering Response Rate**

- Tune speed by operating parallel to and 1.2 m (4 ft) off of the A-B Line.
- Activate AutoTrac Controller and observe performance.
- While tuning, adjust in increments of 10 between the range of 50 to 200.

**Advanced AutoTrac Settings**

**Acquire Sensitivity**

Determines how aggressively the vehicle acquires the track. This setting affects performance while acquiring the track only.

**Higher Settings:** Result in more aggressive line acquisitions.

**Lower Settings:** Result in smoother line acquisitions.



Acquire Sensitivity Too Low



Acquire Sensitivity Too High



5 / 6





Acquire Sensitivity

Continued on next page

CF86321,000027D -19-16MAY11-5/9

PCI3574 — JUN — 04MAY11

**Step 2: Optimize Acquire Sensitivity**

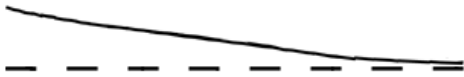

Acquire Sensitivity Too Low



Acquire Sensitivity Too High

- Tune speed by operating parallel to and 1.2 m (4 ft) off of the A-B Line.
- Activate AutoTrac Controller and observe performance.
- Tune Acquire Sensitivity until machine acquires the line smoothly.

PC8797 —UN—21FEB06

PC8796 —UN—21FEB06

PC8999 —UN—08MAR06



A—Desired Track—Broken Line

B—Actual Track—Solid Line

CF86321,000027D -19-16MAY11-6/9

**Step 3: Optimize Line Sensitivity**



Line Sensitivities Too Low



Line Sensitivities Too High

**A: Line Sensitivity—Tracking**

- Tune line sensitivity tracking while operating on the A-B line.
- If machine wanders too far from the A-B line adjust line sensitivity—tracking higher.
- If machine becomes unstable around A-B line adjust line sensitivity—tracking lower.

**B: Line Sensitivity—Heading**

- Tune line sensitivity heading while operating on the A-B line.
- If the front of the machine wanders too far from the track direction adjust line sensitivity—heading higher.
- If machine becomes unstable adjust line sensitivity—heading lower.

PC8794 —UN—08MAR06

PC8795 —UN—08MAR06

PC8999 —UN—08MAR06



A—Desired Track—Broken Line

B—Actual Track—Solid Line

**NOTE:** Line Sensitivities work together—If both are set too high the vehicle will become unstable. If both are set too low, the vehicle will wander around the A-B line.

Continued on next page

CF86321,000027D -19-16MAY11-7/9

**Curve Sensitivity**

Determines how aggressively AutoTrac responds to a curve in the track. This setting affects performance in curve track guidance only.

Higher settings: Turns the vehicle in a smaller radius (tighter) around the curve.

Lower Settings: Turns the vehicle in a larger radius around the curve.

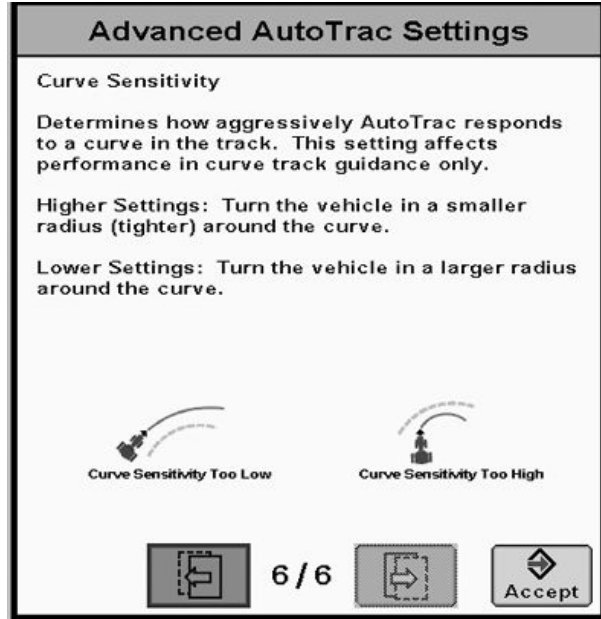

PC13575 —UN—04MAY11

CF86321,000027D -19-16MAY11-8/9

**Curve Sensitivity**



Curve Sensitivity Too Low

PC8944 —UN—21FEB06



Curve Sensitivity Too High

PC8943 —UN—21FEB06

- Tune Curve Sensitivity while operating in Curve Track
- If vehicle turns outside of the curve adjust sensitivity higher
- If vehicle turns inside of the curve adjust sensitivity lower.

PC8999 —UN—08MAR06



A—Desired Track—Broken Line

B—Actual Track—Solid Line

Find the combination of values that works best for the vehicle.

CF86321,000027D -19-16MAY11-9/9

### Tuning Tips, Tricks, and Precautions

• **High Speed/Loose Soil Conditions**

- Tip 1: The main goal with AutoTrac is to minimize off-track error. In many conditions the best results are obtained as the production system is currently tuned with the default settings.
- Tip 2: It has been demonstrated through testing that increased Heading Lead when operating at higher speeds, greater than 11 km/h (7 mph), improves AutoTrac stability.
- Tip 3: Loose soil has a tendency to decrease the ability of the machine to steer when necessary, thereby decreasing performance. To counteract this issue increase the Line Sensitivity Heading. Potential tradeoffs associated with increasing Line Sensitivity Heading are:

1. In some conditions the increased Heading Lead can lead to higher frequency instabilities.
2. Line Sensitivity Heading is used for line acquisitions as well as tracking on line. Therefore, increasing Line Sensitivity Heading can affect line acquisitions.

• **When using AutoTrac to cross previous rows**

- Tip 1: In these circumstances it is common to experience excessive and repeatable side to side motion. Increasing Line Sensitivity Heading and Heading Lead can help reduce the vehicle motion.
- Tip 2: In extreme cases, Differential Lock may be required in addition to the above tip to achieve satisfactory performance.

*NOTE: When increasing Line Sensitivity Heading and Heading Lead, Line Sensitivity Tracking may need to be reduced to prevent excessive wheel motion.*

CF86321.000027E -19-16MAY11-1/1

### Troubleshooting

Symptom	Problem	Solution
<b>AutoTrac controller unstable when entering track</b>	Acquire sensitivity too high	Decrease acquire sensitivity
<b>AutoTrac controller takes too long to enter next track</b>	Acquire sensitivity too low	Increase acquire sensitivity
<b>AutoTrac controller constantly weaves in the row</b>	StarFire Height or Fore-Aft not properly set	Enter correct StarFire Height and Fore-Aft dimension
	Line sensitivities incorrect.	Optimize line sensitivities (See OPTIMIZING AUTOTRAC UNIVERSAL PERFORMANCE in Setup section.)
	StarFire mount direction in SETUP different from actual mount direction	Correctly match TCM SETUP mount direction to actual mount direction
	AutoTrac controller did not establish direction correctly	Drive forward at a speed greater than 1.6 km/h (1 mph) and turn steering wheel greater than 45 degrees in one direction
	Loose Soil	Add Ballast (Follow recommended machine specifications)
<b>AutoTrac Controller drives inside curve</b>	Curve Sensitivity too high	Lower curve sensitivity

CF86321.000027F -19-16MAY11-1/1

# Specifications

## Unified Inch Bolt and Screw Torque Values

TS1671 —UN—01MAY03

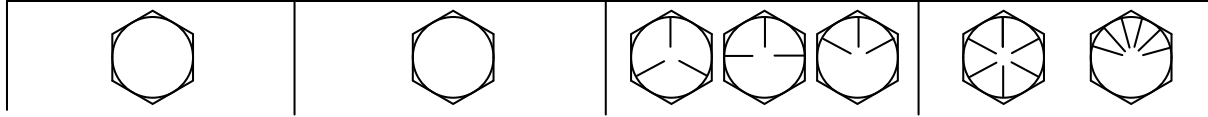

Bolt or Screw Size	SAE Grade 1				SAE Grade 2 <sup>a</sup>				SAE Grade 5, 5.1 or 5.2				SAE Grade 8 or 8.2			
	Lubricated <sup>b</sup>		Dry <sup>c</sup>		Lubricated <sup>b</sup>		Dry <sup>c</sup>		Lubricated <sup>b</sup>		Dry <sup>c</sup>		Lubricated <sup>b</sup>		Dry <sup>c</sup>	
	N·m	lb.-in.	N·m	lb.-in.	N·m	lb.-in.	N·m	lb.-in.	N·m	lb.-in.	N·m	lb.-in.	N·m	lb.-in.	N·m	lb.-in.
1/4	3.7	33	4.7	42	6	53	7.5	66	9.5	84	12	106	13.5	120	17	150
													N·m	lb.-ft.	N·m	lb.-ft.
5/16	7.7	68	9.8	86	12	106	15.5	137	19.5	172	25	221	28	20.5	35	26
									N·m	lb.-ft.	N·m	lb.-ft.				
3/8	13.5	120	17.5	155	22	194	27	240	35	26	44	32.5	49	36	63	46
			N·m	lb.-ft.	N·m	lb.-ft.	N·m	lb.-ft.								
7/16	22	194	28	20.5	35	26	44	32.5	56	41	70	52	80	59	100	74
	N·m	lb.-ft.														
1/2	34	25	42	31	53	39	67	49	85	63	110	80	120	88	155	115
9/16	48	35.5	60	45	76	56	95	70	125	92	155	115	175	130	220	165
5/8	67	49	85	63	105	77	135	100	170	125	215	160	240	175	305	225
3/4	120	88	150	110	190	140	240	175	300	220	380	280	425	315	540	400
7/8	190	140	240	175	190	140	240	175	490	360	615	455	690	510	870	640
1	285	210	360	265	285	210	360	265	730	540	920	680	1030	760	1300	960
1-1/8	400	300	510	375	400	300	510	375	910	670	1150	850	1450	1075	1850	1350
1-1/4	570	420	725	535	570	420	725	535	1280	945	1630	1200	2050	1500	2600	1920
1-3/8	750	550	950	700	750	550	950	700	1700	1250	2140	1580	2700	2000	3400	2500
1-1/2	990	730	1250	930	990	730	1250	930	2250	1650	2850	2100	3600	2650	4550	3350

Torque values listed are for general use only, based on the strength of the bolt or screw. DO NOT use these values if a different torque value or tightening procedure is given for a specific application. For plastic insert or crimped steel type lock nuts, for stainless steel fasteners, or for nuts on U-bolts, see the tightening instructions for the specific application. Shear bolts are designed to fail under predetermined loads. Always replace shear bolts with identical grade.

Replace fasteners with the same or higher grade. If higher grade fasteners are used, tighten these to the strength of the original. Make sure fastener threads are clean and that you properly start thread engagement. When possible, lubricate plain or zinc plated fasteners other than lock nuts, wheel bolts or wheel nuts, unless different instructions are given for the specific application.

<sup>a</sup>Grade 2 applies for hex cap screws (not hex bolts) up to 6 in. (152 mm) long. Grade 1 applies for hex cap screws over 6 in. (152 mm) long, and for all other types of bolts and screws of any length.

<sup>b</sup>"Lubricated" means coated with a lubricant such as engine oil, fasteners with phosphate and oil coatings, or 7/8 in. and larger fasteners with JDM F13C, F13F or F13J zinc flake coating.

<sup>c</sup>"Dry" means plain or zinc plated without any lubrication, or 1/4 to 3/4 in. fasteners with JDM F13B, F13E or F13H zinc flake coating.

IX, FORQ1 -19-12JAN11-1/1

Specifications

**Metric Bolt and Screw Torque Values**

TS1670 —UN—01MAY03

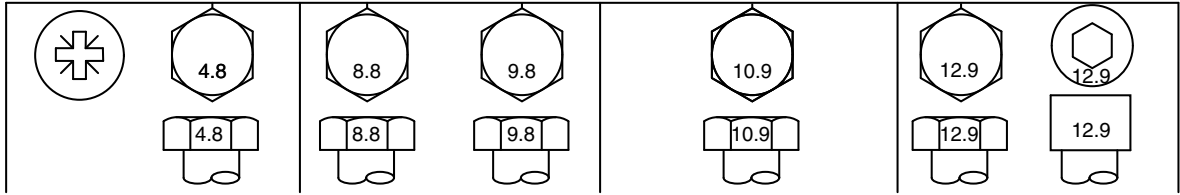

Bolt or Screw Size	Class 4.8				Class 8.8 or 9.8				Class 10.9				Class 12.9			
	Lubricated <sup>a</sup>		Dry <sup>b</sup>		Lubricated <sup>a</sup>		Dry <sup>b</sup>		Lubricated <sup>a</sup>		Dry <sup>b</sup>		Lubricated <sup>a</sup>		Dry <sup>b</sup>	
	N·m	lb.-in.	N·m	lb.-in.	N·m	lb.-in.	N·m	lb.-in.	N·m	lb.-in.	N·m	lb.-in.	N·m	lb.-in.	N·m	lb.-in.
M6	4.7	42	6	53	8.9	79	11.3	100	13	115	16.5	146	15.5	137	19.5	172
M8	11.5	102	14.5	128	22	194	27.5	243	32	23.5	40	29.5	37	27.5	47	35
M10	23	204	29	21	43	32	55	40	63	46	80	59	75	55	95	70
M12	40	29.5	50	37	75	55	95	70	110	80	140	105	130	95	165	120
M14	63	46	80	59	120	88	150	110	175	130	220	165	205	150	260	190
M16	100	74	125	92	190	140	240	175	275	200	350	255	320	235	400	300
M18	135	100	170	125	265	195	330	245	375	275	475	350	440	325	560	410
M20	190	140	245	180	375	275	475	350	530	390	675	500	625	460	790	580
M22	265	195	330	245	510	375	650	480	725	535	920	680	850	625	1080	800
M24	330	245	425	315	650	480	820	600	920	680	1150	850	1080	800	1350	1000
M27	490	360	625	460	950	700	1200	885	1350	1000	1700	1250	1580	1160	2000	1475
M30	660	490	850	625	1290	950	1630	1200	1850	1350	2300	1700	2140	1580	2700	2000
M33	900	665	1150	850	1750	1300	2200	1625	2500	1850	3150	2325	2900	2150	3700	2730
M36	1150	850	1450	1075	2250	1650	2850	2100	3200	2350	4050	3000	3750	2770	4750	3500

Torque values listed are for general use only, based on the strength of the bolt or screw. DO NOT use these values if a different torque value or tightening procedure is given for a specific application. For stainless steel fasteners or for nuts on U-bolts, see the tightening instructions for the specific application. Tighten plastic insert or crimped steel type lock nuts by turning the nut to the dry torque shown in the chart, unless different instructions are given for the specific application.

Shear bolts are designed to fail under predetermined loads. Always replace shear bolts with identical property class. Replace fasteners with the same or higher property class. If higher property class fasteners are used, tighten these to the strength of the original. Make sure fastener threads are clean and that you properly start thread engagement. When possible, lubricate plain or zinc plated fasteners other than lock nuts, wheel bolts or wheel nuts, unless different instructions are given for the specific application.

<sup>a</sup>"Lubricated" means coated with a lubricant such as engine oil, fasteners with phosphate and oil coatings, or M20 and larger fasteners with JDM F13C, F13F or F13J zinc flake coating.

<sup>b</sup>"Dry" means plain or zinc plated without any lubrication, or M6 to M18 fasteners with JDM F13B, F13E or F13H zinc flake coating.

DX,TORQ2 -19-12JAN11-1/1

Specifications

**EC Declaration of Conformity**

**Deere & Company  
Moline, Illinois U.S.A.**

The person named below declares that

Product: AutoTrac™ Controller

fulfills all relevant provisions and essential requirements of the following directives:

Directive	Number	Certification Method
Electromagnetic Compatibility Directive	2004/108/EC	Self certified, per Annex II of the Directive

Name and address of the person in the European Community authorized to compile the technical construction file:

Brigitte Birk  
Deere & Company European Office  
John Deere Strasse 70  
Mannheim, Germany D-68163  
EUConformity@JohnDeere.com

Place of declaration: Kaiserslautern, Germany

Date of declaration: 29 July 2011

Manufacturing unit: John Deere Intelligent Solutions Group

Name: Aaron Senneff

Title: Engineering Manager, John Deere Intelligent Solutions Group



DXCE01 — UN — 28APR09

BA31779,000024A -19-01AUG11-1/1

# Index

	Page		Page
<b>A</b>			
Acquire Sensitivity .....	45-6	Current Controller	
Acquired Sensitivity .....	40-4	AutoTrac Controller .....	25-4
Addresses		Curve Sensitivity .....	40-4, 45-8
Diagnostics .....	35-1, 35-5	<b>D</b>	
Advanced Settings .....	45-5	Deactivating	
Acquire Sensitivity .....	45-6	AutoTrac .....	40-3
Curve Sensitivity .....	45-8	Deactivating AutoTrac .....	30-8
Heading Lead .....	45-5	Diagnostic Addresses .....	35-5
Line Sensitivity Tracking .....	45-4	Diagnostic Readings	
Optimizing AutoTrac Controller Performance .....	45-4	AutoTrac Controller .....	20-2
Steering Response Rate .....	45-6	Diagnostics	
AutoTrac		Addresses .....	35-1, 35-5
Activating System .....	30-1, 40-3	AutoTrac .....	35-3
Deactivate .....	30-8, 40-3	GPS .....	35-3
Enabling System .....	30-1, 40-2	Steering Controller .....	35-3
Tractor		Trouble Codes .....	25-10, 25-12, 35-1
Conditions for Activation .....	25-9	<b>G</b>	
AutoTrac Controller		Guidance	
Calibration .....	25-1	Warnings .....	35-3
Current Controller .....	25-4	<b>H</b>	
Entering Setup Menu .....	25-3	Hardware torque values	
General Information .....	15-1	Metric .....	50-2
Left Turning Diameter .....	25-8	Unified inch .....	50-1
Main Menu .....	25-2	Heading Lead .....	45-5
Pressure Sensor Calibration .....	25-7	<b>L</b>	
Pressure Sensor Calibration - Standby Pressure .....	25-7	Line Sensitivity	
Right Turning Diameter .....	25-8	Heading .....	40-4
Setup Menu .....	25-3	Tracking .....	40-4
Standby Pressure .....	25-7	Line Sensitivity Heading .....	45-5
Tractor Turning Diameter .....	25-7	Line Sensitivity Tracking .....	45-4
Troubleshooting .....	20-1	<b>M</b>	
Turning Diameter .....	25-7	Main Menu	
Turning Diameter – Left .....	25-8	AutoTrac Controller .....	25-2
Turning Diameter – Right .....	25-8	Master Switch .....	30-8, 40-3
Valve Deadband .....	25-5	Metric bolt and screw torque values .....	50-2
Valve Deadband Left .....	25-5	<b>O</b>	
Valve Deadband Right .....	25-5	Operation (AutoTrac Controller)	
Vehicle Code .....	25-3	Activity Monitor .....	15-2
Wheel Angle Sensor .....	25-6	AutoTrac Settings .....	15-2
Wheel Angle Sensor Center Calibration .....	25-6	Operator Detection Timeout .....	15-2
Wheel Angle Sensor Left Calibration .....	25-6	Operator Presense .....	40-4
Wheel Angle Sensor Right Calibration .....	25-6	<b>C</b>	
Wheelbase .....	25-4	Calibration	
<b>B</b>			
Bolt and screw torque values		AutoTrac Controller .....	25-1
Metric .....	50-2		
Unified inch .....	50-1		
<b>C</b>			

Continued on next page

	Page		Page
		<b>P</b>	
Pressure Sensor Calibration - Standby		Valve Deadband Right	
Pressure		AutoTrac Controller.....	25-5
AutoTrac Controller.....	25-7	Vehicle Code	
		AutoTrac Controller.....	25-3
		Vehicle Type.....	40-4
		<b>R</b>	
Recommended Tuning Settings.....	45-3	Wheel Angle Sensor Center Calibration	
Reichhardt.....	25-1	AutoTrac Controller.....	25-6
		Wheel Angle Sensor Left Calibration	
		AutoTrac Controller.....	25-6
		Wheel Angle Sensor Right Calibration	
		AutoTrac Controller.....	25-6
		Wheelbase	
		AutoTrac Controller.....	25-4
		<b>S</b>	
Setup Menu			
AutoTrac Controller.....	25-3		
StarFire Fore-Aft.....	40-4		
StarFire Height.....	40-4		
StarFire Setup.....	30-16		
Steer Asymmetry.....	40-4		
Steer Play.....	40-4		
Steer Wheel Speed.....	40-4		
Steering Response Rate.....	45-6		
		<b>T</b>	
Torque charts			
Metric.....	50-2		
Unified inch.....	50-1		
Tractor			
AutoTrac			
Conditions for Activation.....	25-9		
Tractor Turning Diameter			
AutoTrac Controller.....	25-7		
Trouble Codes.....	25-10, 25-12, 35-1		
Troubleshooting			
AutoTrac.....	35-3		
AutoTrac Universal.....	20-1		
Diagnostic Addresses.....	35-1, 35-5		
GPS.....	35-3		
Steering Controller.....	35-3		
Trouble Codes.....	25-10, 25-12, 35-1		
Troubleshooting (AutoTrac Controller)			
Stop Codes.....	20-3		
Tuning Recommendations.....	45-1		
Tuning Tips, Tricks, and Precautions.....	45-9		
Turning Diameter – Left			
AutoTrac Controller.....	25-8		
Turning Diameter – Right			
AutoTrac Controller.....	25-8		
		<b>U</b>	
Unified inch bolt and screw torque values.....	50-1		
		<b>V</b>	
Valve Deadband Left			
AutoTrac Controller.....	25-5		

# John Deere Service Literature Available

## Technical Information

Technical information can be purchased from John Deere. Some of this information is available in electronic media, such as CD-ROM disks, and in printed form. There are many ways to order. Contact your John Deere dealer. Call **1-800-522-7448** to order using a credit card. Search online from <http://www.JohnDeere.com>. Please have available the model number, serial number, and name of the product.

Available information includes:

- **PARTS CATALOGS** list service parts available for your machine with exploded view illustrations to help you identify the correct parts. It is also useful in assembling and disassembling.
- **OPERATOR'S MANUALS** providing safety, operating, maintenance, and service information. These manuals and safety signs on your machine may also be available in other languages.
- **OPERATOR'S VIDEO TAPES** showing highlights of safety, operating, maintenance, and service information. These tapes may be available in multiple languages and formats.
- **TECHNICAL MANUALS** outlining service information for your machine. Included are specifications, illustrated assembly and disassembly procedures, hydraulic oil flow diagrams, and wiring diagrams. Some products have separate manuals for repair and diagnostic information. Some components, such as engines, are available in separate component technical manuals
- **FUNDAMENTAL MANUALS** detailing basic information regardless of manufacturer:
  - Agricultural Primer series covers technology in farming and ranching, featuring subjects like computers, the Internet, and precision farming.
  - Farm Business Management series examines "real-world" problems and offers practical solutions in the areas of marketing, financing, equipment selection, and compliance.
  - Fundamentals of Services manuals show you how to repair and maintain off-road equipment.
  - Fundamentals of Machine Operation manuals explain machine capacities and adjustments, how to improve machine performance, and how to eliminate unnecessary field operations.



TS189 —UN—17JAN89



TS191 —UN—02DEC88



TS224 —UN—17JAN89



TS1663 —UN—10OCT97

DX.SERV.LIT -19-31.JUL03-1/1



# John Deere Service Keeps You On Job

## John Deere Is At Your Service

CUSTOMER SATISFACTION is important to John Deere.

Our dealers strive to provide you with prompt, efficient parts and service:

- Maintenance and service parts to support your equipment.
- Trained service technicians and the necessary diagnostic and repair tools to service your equipment.



## CUSTOMER SATISFACTION PROBLEM RESOLUTION PROCESS

Your John Deere dealer is dedicated to supporting your equipment and resolving any problem you may experience.

1. When contacting your dealer, be prepared with the following information:

- Machine model and product identification number
- Date of purchase
- Nature of problem

2. Discuss problem with dealer service manager.

3. If unable to resolve, explain problem to dealership manager and request assistance.

4. If you have a persistent problem your dealership is unable to resolve, ask your dealer to contact John Deere for assistance. Or contact the Ag Customer Assistance Center at 1-866-99DEERE (866-993-3373) or e-mail us at [www.deere.com/en\\_US/ag/contactus/](http://www.deere.com/en_US/ag/contactus/).

TS201 — UN—23AUG88

DX,IBC,2 -19-02APR02-1/1

