



Smartboom Installation Manual

Rogator 864, 1064, 874, 1074
(Dec. 2005 and Older)

CHAPTER

1

INTRODUCTION

Congratulations on your purchase of the Raven Smartboom system! This system is designed to provide worry-free turn on and turn off of your booms with respect to an as-applied area. The following instructions are designed to assist you in the proper installation of the Smartboom system. See the Operation Manual of your Smartboom console for instructions on setting up the software and using the Smartboom system.



Important! All boom switches must be in the OFF position and the master switch must be in the ON position while Smartboom is in operation!

Notes:

CHAPTER

2

INSTALLATION

Use the following procedure to properly install the Smartboom system.

1. Locate the 8 pin armrest harness connector behind the armrest.
2. Disconnect and tee in the Smartboom harness.
3. Locate the single packard master switch connector on the armrest harness. Disconnect and tee in the master switch tee on the Smartboom harness.

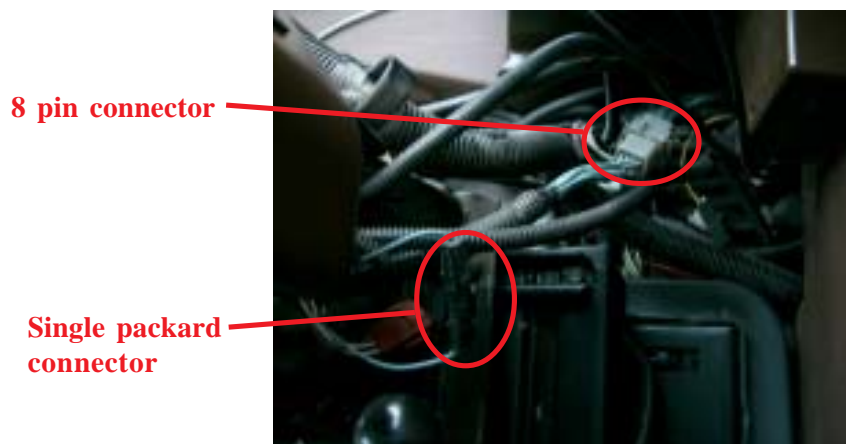

4. Connect the power leads to a good source of switched power.
5. Installation is now complete.
6. Refer to the Smartboom Operators manual for console setup instructions.

864/1064/874/1074 (DEC. 2005 AND OLDER) ROGATOR SMARTBOOM SYSTEM INSTALL SCHEMATIC

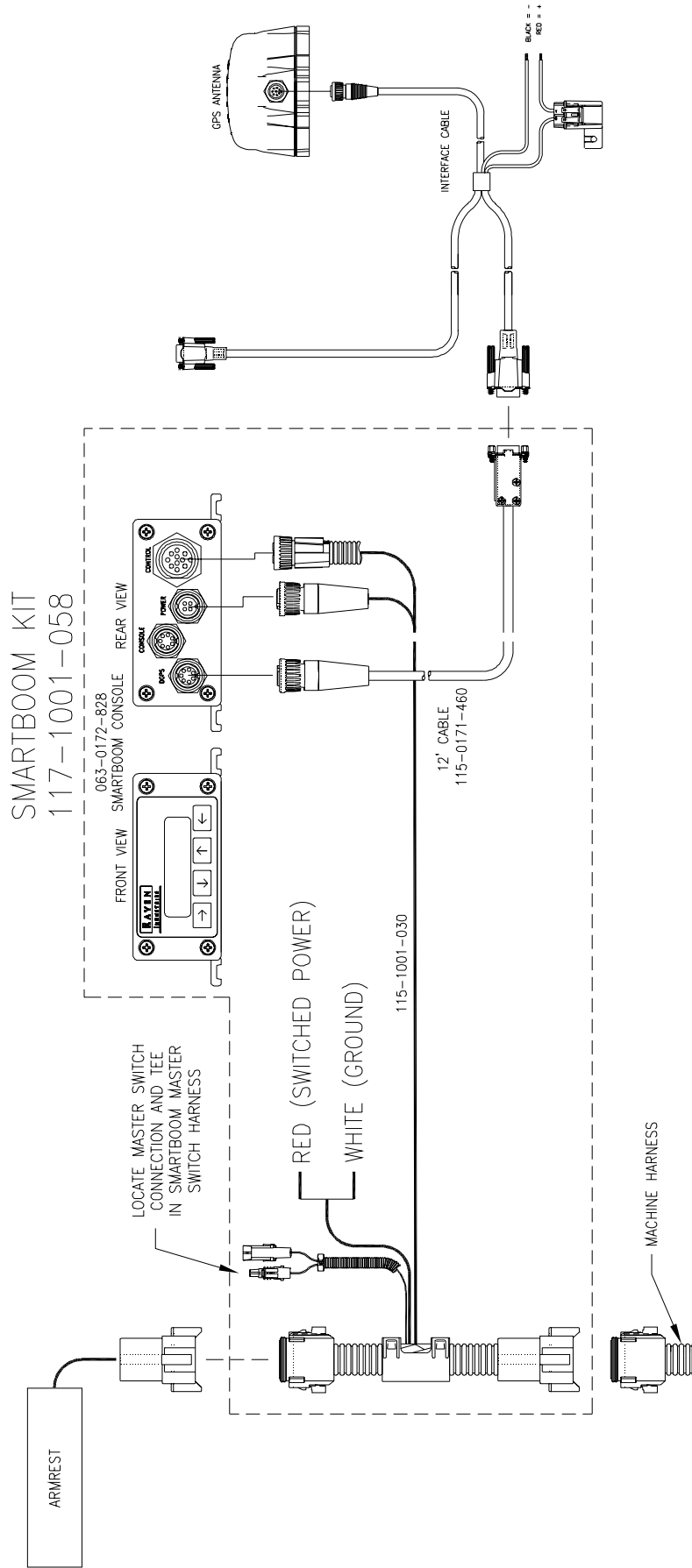



RAVEN INDUSTRIES LIMITED WARRANTY

WHAT IS COVERED?

This warranty covers all defects in workmanship or materials in your Raven Flow Control Product under normal use, maintenance, and service.

HOW LONG IS THE COVERAGE PERIOD?

This warranty coverage runs for 12 months from the purchase date of your Raven Flow Control Product. This warranty coverage applies only to the original owner and is not transferrable.

HOW CAN YOU GET SERVICE?

Bring the defective part, and proof of date of purchase, to your local dealer. If your dealer agrees with the warranty claim, he will send the part, and proof of purchase to his distributor or to Raven for final approval.

WHAT WILL RAVEN INDUSTRIES DO?

When our inspection proves the warranty claim, we will, at our option, repair or replace the defective part and pay for return freight.

WHAT DOES THIS WARRANTY NOT COVER?

Raven Industries will not assume any expense or liability for repairs made outside our plant without written consent. We are not responsible for damage to any associated equipment or product and will not be liable for loss of profit or other special damages. The obligation of this warranty is in lieu of all other warranties, expressed or implied, and no person is authorized to assume for us any liability. Damages caused by normal wear and tear, misuse, abuse, neglect, accident, or improper installation and maintenance are not covered by this warranty.



Raven Industries
Flow Controls Division
P.O. Box 5107
Sioux Falls, SD 57117-5107

Toll Free 800-243-5435
Fax 605-331-0426
www.ravenprecision.com
fcinfo@ravenind.com

Notice: This document and the information provided are the property of Raven Industries, Inc. and may only be used as authorized by Raven Industries, Inc. All rights reserved under the copyright laws.